

- 5.1 What the System Link Budget Tells the System Engineer, 243
- 5.2 The Channel, 244
 - 5.2.1 *The Concept of Free Space*, 244
 - 5.2.2 *Error-Performance Degradation*, 245
 - 5.2.3 *Sources of Signal Loss and Noise*, 245
- 5.3 Received Signal Power and Noise Power, 250
 - 5.3.1 *The Range Equation*, 250
 - 5.3.2 *Received Signal Power as a Function of Frequency*, 254
 - 5.3.3 *Path Loss is Frequency Dependent*, 256
 - 5.3.4 *Thermal Noise Power*, 258
- 5.4 Link Budget Analysis, 259
 - 5.4.1 *Two E_b/N_0 Values of Interest*, 262
 - 5.4.2 *Link Budgets are Typically Calculated in Decibels*, 263
 - 5.4.3 *How Much Link Margin is Enough?* 264
 - 5.4.4 *Link Availability*, 266
- 5.5 Noise Figure, Noise Temperature, and System Temperature, 270
 - 5.5.1 *Noise Figure*, 270
 - 5.5.2 *Noise Temperature*, 273
 - 5.5.3 *Line Loss*, 274
 - 5.5.4 *Composite Noise Figure and Composite Noise Temperature*, 276
 - 5.5.5 *System Effective Temperature*, 277
 - 5.5.6 *Sky Noise Temperature*, 282
- 5.6 Sample Link Analysis, 286
 - 5.6.1 *Link Budget Details*, 287
 - 5.6.2 *Receiver Figure of Merit*, 289
 - 5.6.3 *Received Isotropic Power*, 289
- 5.7 Satellite Repeaters, 290
 - 5.7.1 *Nonregenerative Repeaters*, 291
 - 5.7.2 *Nonlinear Repeater Amplifiers*, 295
- 5.8 System Trade-Offs, 296
- 5.9 Conclusion, 297

Communications Link Analysis

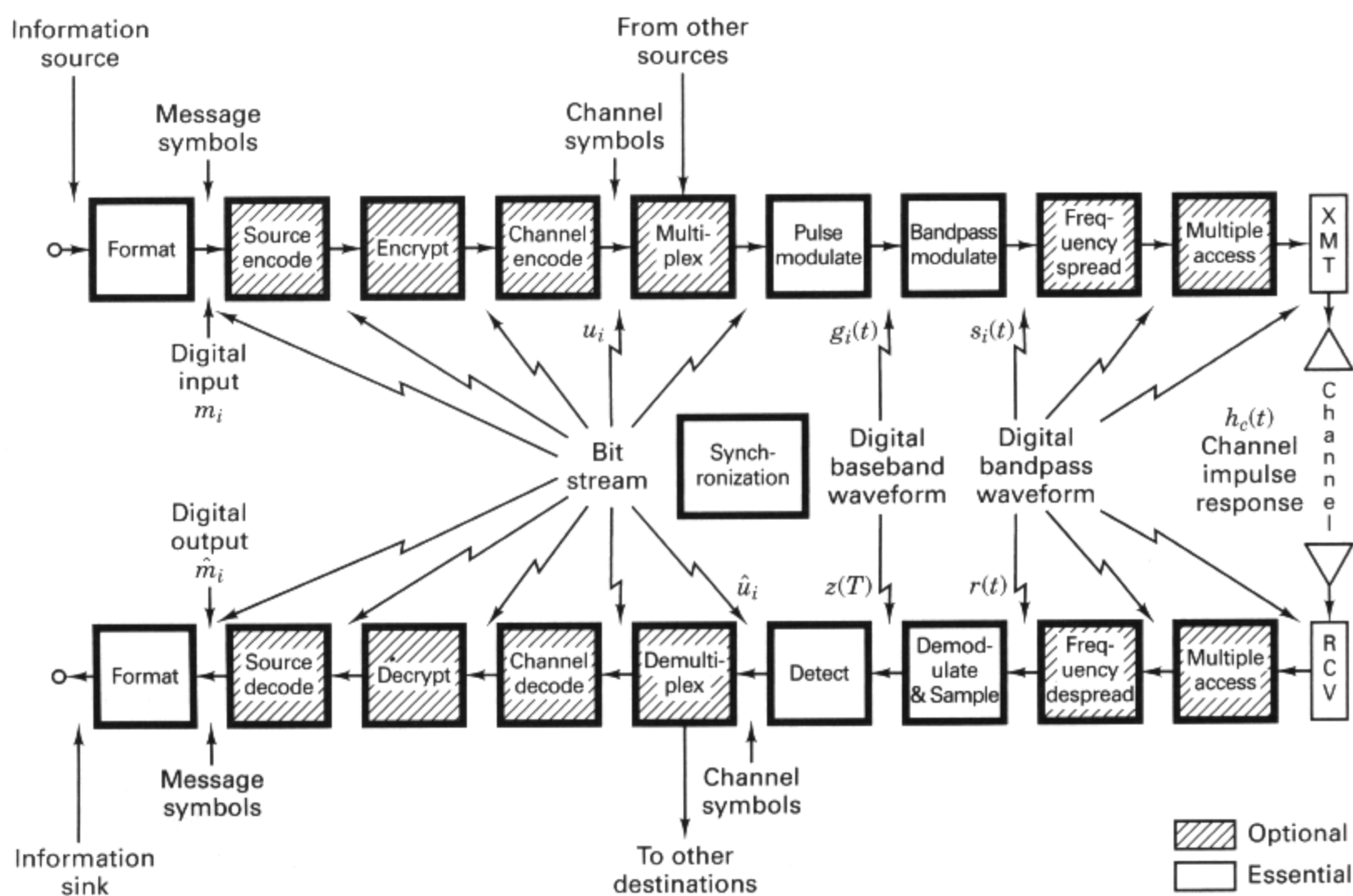

5.1 WHAT THE SYSTEM LINK BUDGET TELLS THE SYSTEM ENGINEER

When we talk about a communications *link*, to what part of the system are we referring? Is it simply the channel or region between the transmitter and receiver? No, it is far more than that. The link encompasses the entire communications path, from the information source, through all the encoding and modulation steps, through the transmitter and the channel, up to and including the receiver with all its signal processing steps, and terminating at the information sink.

What is a link analysis, and what purpose does it serve in the development of a communication system? The link analysis, and its output, the *link budget*, consist of the calculations and tabulation of the useful signal power and the interfering noise power available at the receiver. The link budget is a balance sheet of gains and losses; it outlines the detailed apportionment of transmission and reception resources, noise sources, signal attenuators, and effects of processes throughout the link. Some of the budget parameters are statistical (e.g., allowances for the fading of signals as described in Chapter 15). The budget is an *estimation* technique for evaluating communication system error performance. In Chapters 3 and 4 we examined probability of error versus E_b/N_0 curves having a “waterfall-like” shape, such as the one shown in Figure 3.6. We thereby related error probability to E_b/N_0 for various modulation types in Gaussian noise. Once a modulation scheme has been chosen, the requirement to meet a particular error probability dictates a particular operating point on the curve; in other words, the required error perfor-

mance dictates the value of E_b/N_0 that must be made available at the receiver in order to meet that performance. The primary purpose of a link analysis is to determine the *actual* system operating point in Figure 3.6 and to establish that the error probability associated with that point is less than or equal to the system requirement. Of the many specifications, analyses, and tabulations that are used in the development of a communication system, the link budget stands out as a basic tool for providing the system engineer with overall system insight.

By examining the link budget, one can learn many things about overall system design and performance. For example, from the link margin, one learns whether the system will meet many of its requirements comfortably, marginally, or not at all. The link budget may reveal if there are any hardware constraints, and whether such constraints can be compensated for in other parts of the link. The link budget is often used as a “score sheet” in considering system trade-offs and configuration changes, and in understanding subsystem nuances and interdependencies. From a quick examination of the link budget and its supporting documentation, one can judge whether the analysis was done precisely or if it represents a rough estimate. Together with other modeling techniques, the link budget can help predict equipment weight, size, prime power requirements, technical risk, and cost. The link budget is one of the system manager’s most useful documents; it represents the “bottom-line” tally in the search for optimum system performance.

5.2 THE CHANNEL

The propagating medium or electromagnetic path connecting the transmitter and receiver is called the *channel*. In general, a communications channel might consist of wires, coaxial cables, fiber optic cables, and in the case of radio-frequency (RF) links, waveguides, the atmosphere, or empty space. For most terrestrial communication links, the channel space is occupied by the atmosphere and partially bounded by the earth’s surface. For satellite links, the channel is occupied mostly by empty space. Although some atmospheric effects occur at altitudes up to 100 km, the *bulk* of the atmosphere extends to an altitude of 20 km. Therefore, only a small part (0.05%) of the total synchronous altitude (35,800 km) path is occupied by significant amounts of atmosphere. Most of this chapter presents link analysis in the context of such a satellite communications link. In Chapter 15, the link budget issues are extended to terrestrial wireless links.

5.2.1 The Concept of Free Space

The concept of *free space* assumes a channel free of all hindrances to RF propagation, such as absorption, reflection, refraction, or diffraction. If there is any atmosphere in the channel, it must be perfectly uniform and meet all these conditions. Also, we assume that the earth is infinitely far away or that its reflection coefficient is negligible. The RF energy arriving at the receiver is assumed to be a function only of distance from the transmitter (following the inverse-square law as used in

optics). A free-space channel characterizes an ideal RF propagation path; in practice, propagation through the atmosphere and near the ground results in absorption, reflection, diffraction and scattering, which modify the free-space transmission. Atmospheric absorption is treated in later sections. Reflection, diffraction, and scattering, which play an important role in determining terrestrial communications performance, are treated in Chapter 15. Also, Panter [1] provides a comprehensive treatment of these mechanisms.

5.2.2 Error-Performance Degradation

In Chapter 3, it was established that there are two primary causes for degradation of error performance. The first is loss in signal-to-noise ratio. The second is signal distortion as might be caused by intersymbol interference (ISI). In Chapters 3 and 15, some of the equalization techniques to counter the degradation effect of ISI are treated. In this chapter, we are concerned with the “bookkeeping” of the gains and losses for signal power and interfering power. ISI will not be included in the link budget because the uniqueness of ISI is that an increase in signal power will not always mitigate the degradation that it causes. (See Section 3.3.2.)

For digital communications, error performance depends on the received E_b/N_0 , which was defined in Equation (3.30) as

$$\frac{E_b}{N_0} = \frac{S}{N} \left(\frac{W}{R} \right)$$

In other words, E_b/N_0 is a measure of normalized signal-to-noise ratio (S/N or SNR). Unless otherwise stated, SNR refers to *average* signal power and *average* noise power. The signal can be an information signal, a baseband waveform, or a modulated carrier. The SNR can degrade in two ways: (1) through the decrease of the desired signal power, and (2) through the increase of noise power, or the increase of interfering signal power. Let us refer to these degradations as *loss* and *noise* (or *interference*), respectively. Losses occur when a portion of the signal is absorbed, diverted, scattered, or reflected along its route to the intended receiver; thus a portion of the transmitted energy does not arrive at the receiver. There are several sources of interfering electrical noise and interference produced by a variety of mechanisms and sources, such as thermal noise, galaxy noise, atmospheric noise, switching transients, intermodulation noise, and interfering signals from other sources. Industry usage of the terms *loss* and *noise* frequently confuses the underlying degradation mechanism; however, the net effect on the SNR is the same.

5.2.3 Sources of Signal Loss and Noise

Figure 5.1 is a block diagram of a satellite communications link, emphasizing the sources of signal loss and noise. In the figure a signal loss is distinguished from a noise source by a dot pattern or line pattern, respectively. The contributors of *both* signal loss *and* noise are identified by a crosshatched line pattern. The following list of 21

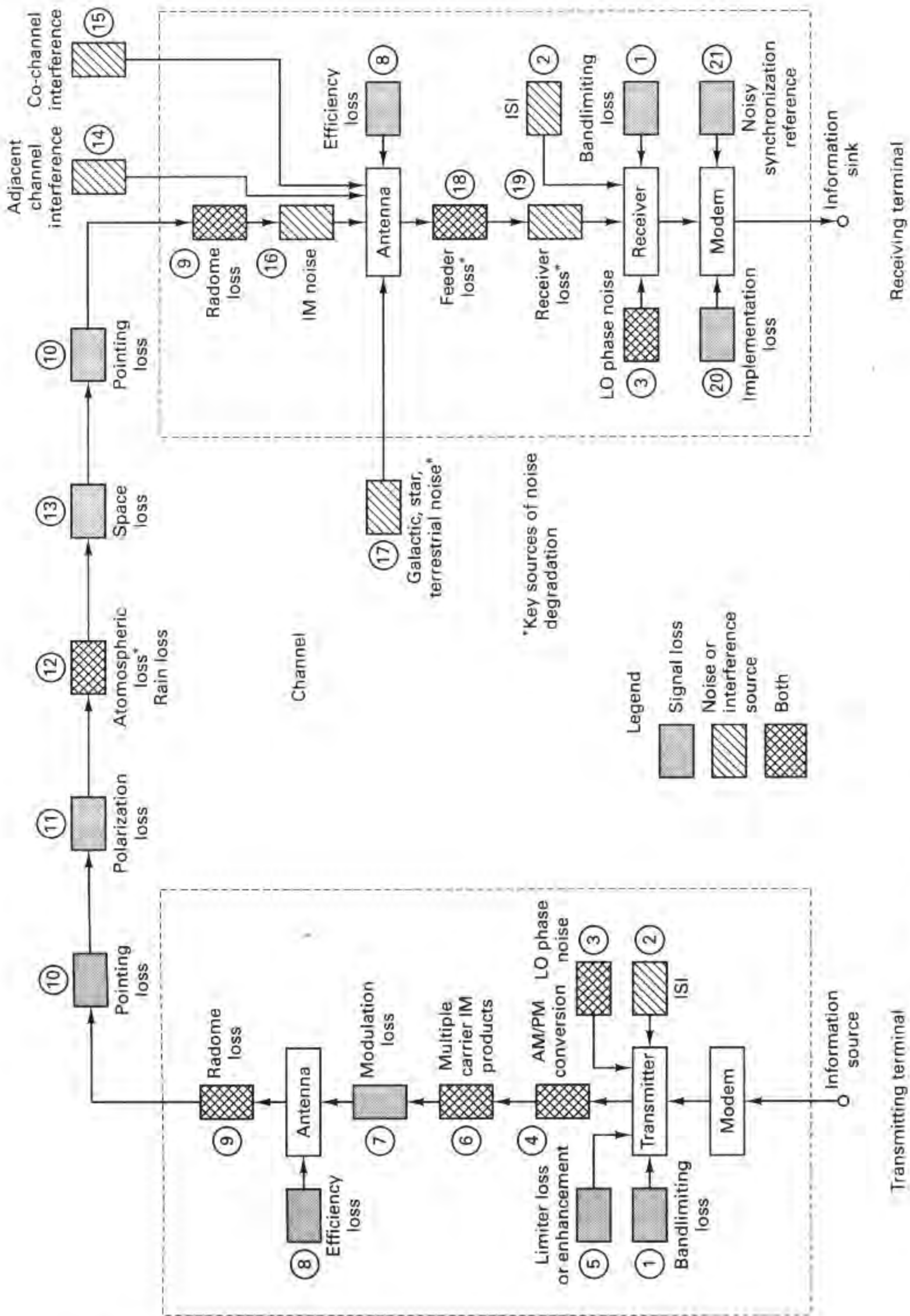

Figure 5.1 Satellite transmitter-to-receiver link with typical loss and noise sources.

sources of degradation represents a partial catalog of the major contributors to SNR degradation. The numbers correspond to the numbered circles in Figure 5.1.

1. *Bandlimiting loss.* All systems use filters in the transmitter to ensure that the transmitted energy is confined to the allocated or assigned bandwidth. This is to avoid interfering with other channels or users and to meet the requirements of regulatory agencies. Such filtering reduces the total amount of energy that would otherwise have been transmitted; the result is a *loss* in signal.
2. *Intersymbol interference (ISI).* As discussed in Chapter 3, filtering throughout the system—in the transmitter, in the receiver, and in the channel—can result in ISI. The received pulses overlap one another; the tail of one pulse “smears” into adjacent symbol intervals so as to *interfere* with the detection process. Even in the absence of thermal noise, imperfect filtering, system bandwidth constraints, and fading channels lead to ISI degradation.
3. *Local oscillator (LO) phase noise.* When an LO is used in signal mixing, phase fluctuations or jitter adds phase *noise* to the signal. When used as the reference signal in a receiver correlator, phase jitter can cause detector degradation and hence signal *loss*. At the transmitter, phase jitter can cause out-of-band signal spreading, which, in turn, will be filtered out and cause a *loss* in signal.
4. *AM/PM conversion.* AM-to-PM conversion is a phase *noise* phenomenon occurring in nonlinear devices such as traveling-wave tubes (TWT). Signal amplitude fluctuations (amplitude modulation) produce phase variations that contribute phase *noise* to signals that will be coherently detected. AM-to-PM conversion can also cause extraneous sidebands, resulting in signal *loss*.
5. *Limiters loss or enhancement.* A hard limiter can enhance the stronger of two signals, and suppress the weaker; this can result in either a signal *loss* or a signal *gain* [2].
6. *Multiple-carrier intermodulation (IM) products.* When several signals having different carrier frequencies are simultaneously present in a nonlinear device, such as a TWT, the result is a multiplicative interaction between the carrier frequencies which can produce signals at all combinations of sum and difference frequencies. The energy apportioned to these spurious signals (intermodulation or IM products) represents a *loss* in signal energy. In addition, if these IM products appear within the bandwidth region of these or other signals, the effect is that of added *noise* for those signals.
7. *Modulation loss.* The link budget is a calculation of received useful power (or energy). Only the power associated with information-bearing signals is useful. Error performance is a function of energy per transmitted symbol. Any power used for transmitting the carrier rather than the modulating signal (symbols) is a modulation *loss*. (However, energy in the carrier may be useful in aiding synchronization.)
8. *Antenna efficiency.* Antennas are transducers that convert electronic signals into electromagnetic fields, and vice versa. They are also used to focus the

electromagnetic energy in a desired direction. The larger the antenna aperture (area), the larger is the resulting signal power density in the desired direction. An antenna's efficiency is described by the ratio of its effective aperture to its physical aperture. Mechanisms contributing to a reduction in efficiency (*loss* in signal strength) are known as amplitude tapering, aperture blockage, scattering, re-radiation, spillover, edge diffraction, and dissipative loss [3]. Typical efficiencies due to the combined effects of these mechanisms range between 50 and 80%.

9. *Radome loss and noise.* A radome is a protective cover, used with some antennas, for shielding against weather effects. The radome, being in the path of the signal, will scatter and absorb some of the signal energy, thus resulting in a signal *loss*. A basic law of physics holds that a body capable of absorbing energy also radiates energy (at temperatures above 0 K). Some of this energy falls in the bandwidth of the receiver and constitutes injected *noise*.
10. *Pointing loss.* There is a *loss* of signal when either the transmitting antenna or the receiving antenna is imperfectly pointed.
11. *Polarization loss.* The polarization of an electromagnetic (EM) field is defined as the direction in space along which the field lines point, and the polarization of an antenna is described by the polarization of its radiated field. There is a *loss* of signal due to any polarization mismatch between the transmitting and receiving antennas.
12. *Atmospheric loss and noise.* The atmosphere is responsible for signal loss and is also a contributor of unwanted noise. The bulk of the atmosphere extends to an altitude of approximately 20 km; yet within that relatively short path, important loss and noise mechanisms are at work. Figure 5.2 is a plot of the theoretical one-way attenuation from a specified height to the top of the atmosphere. The calculations were made for several heights (0 km is sea level) and for a water vapor content of 7.5 g/m^3 at the earth's surface. The magnitude of signal *loss* due to oxygen (O_2) and water vapor absorption is plotted as a function of carrier frequency. Local maxima of attenuation occur in the vicinities of 22 GHz (water vapor), and 60 and 120 GHz (O_2). The atmosphere also contributes *noise* energy into the link. As in the case of the radome, molecules that absorb energy also radiate energy. The oxygen and water vapor molecules radiate noise throughout the RF spectrum. The portion of this noise that falls within the bandwidth of a given communication system will degrade its SNR. A primary atmospheric cause of signal *loss* and contributor of *noise* is rainfall. The more intense the rainfall, the more signal energy it will absorb. Also, on a day when rain passes through the antenna beam, there is a larger amount of atmospheric noise radiated into the system receiver than there is on a clear day. More will be said about atmospheric noise in later sections.
13. *Space loss.* There is a decrease in the electric field strength, and thus in signal strength (power density or flux density), as a function of distance. For a satellite communications link, the space loss is the largest single *loss* in the

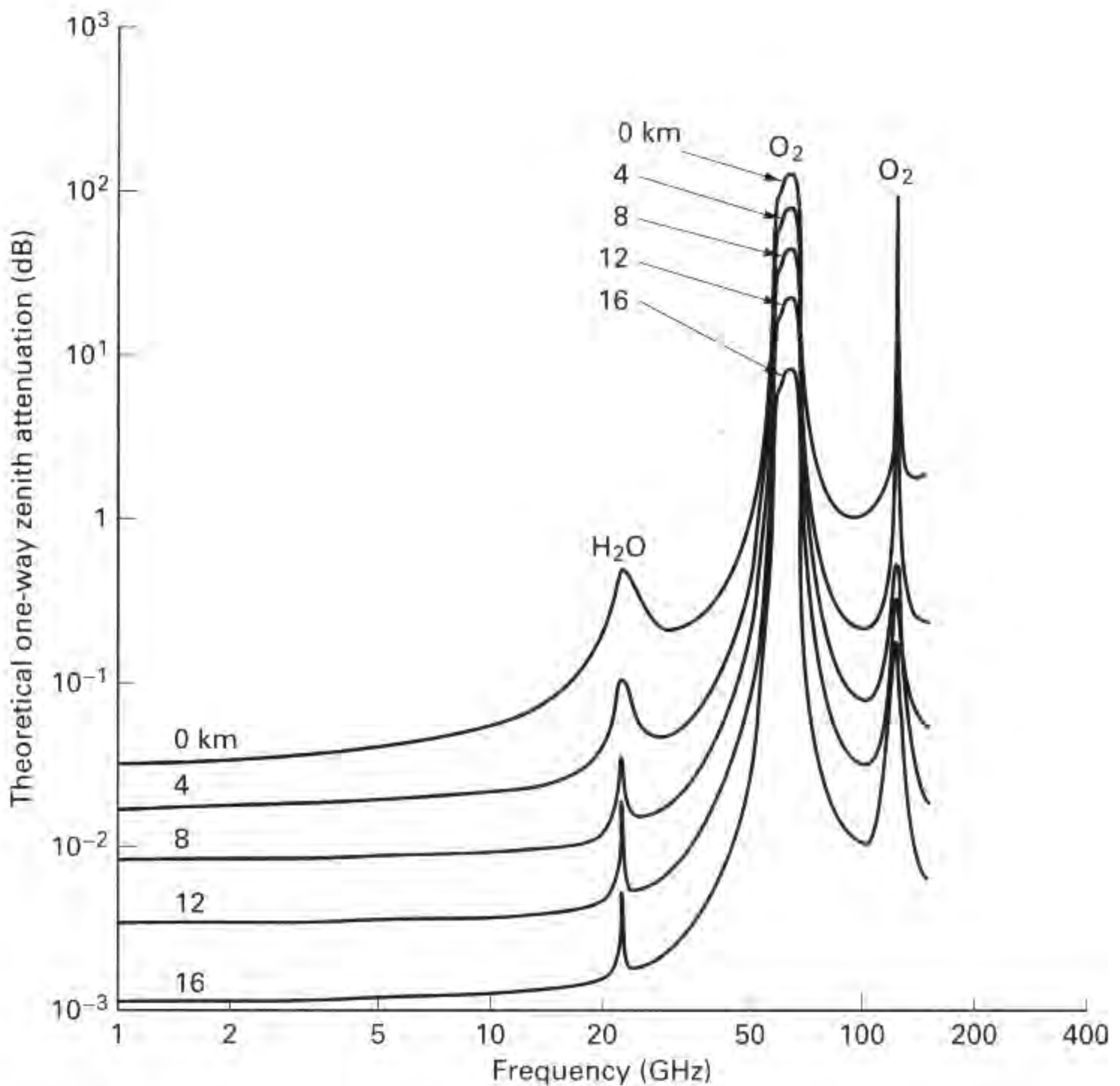

Figure 5.2 Theoretical vertical one-way attenuation from specified height to top of atmosphere for 7.5 g/m^3 of water vapor at the surface. (Does not include effect of rain or cloud attenuation.) (Reprinted from NASA Reference Publication 1082(03), "Propagation Effects Handbook for Satellite Systems Design," June 1983, Fig. 6.2-1, p. 218, courtesy of the National Aeronautics and Space Administration.)

system. It is a loss in the sense that all the radiated energy is not focused on the intended receiving antenna.

14. *Adjacent channel interference.* This *interference* is characterized by unwanted signals from other frequency channels "spilling over" or injecting energy into the channel of interest. The proximity with which channels can be located in frequency is determined by the modulation spectral roll-off and the width and shape of the main spectral lobe.
15. *Co-channel interference.* This *interference* refers to the degradation caused by an interfering waveform appearing within the signal bandwidth. It can be intro-

duced by a variety of ways, such as accidental transmissions, insufficient vertical and horizontal polarization discrimination, or by radiation spillover from an antenna sidelobe (low-energy beam surrounding the main antenna beam). It can be brought about by other authorized users of the same spectrum.

16. *Intermodulation (IM) noise.* The IM products described in item 6 result from multiple-carrier signals interacting in a nonlinear device. Such IM products are sometimes called *active intermods*; as described in item 6, they can either cause a loss in signal energy or be responsible for noise injected into a link. Here we consider *passive intermods*; these are caused by multiple-carrier transmission signals interacting with nonlinear components at the transmitter output. These nonlinearities generally occur at the junction of waveguide coupling joints, at corroded surfaces, and at surfaces having poor electrical contact. When large EM fields impinge on surfaces that have a diode-like transfer function (work potential), they cause multiplicative products, and hence *noise*. If such noise radiates into a closely located receiving antenna, it can seriously degrade the receiver performance.
17. *Galactic or cosmic, star, and terrestrial noise.* All the celestial bodies, such as the stars and the planets, radiate energy. Such *noise* energy in the field of view of the antenna will degrade the SNR.
18. *Feeder line loss.* The level of the received signal might be very small (e.g., 10^{-12} W), and thus will be particularly susceptible to noise degradation. The receiver front end, therefore, is a region where great care is taken to keep the noise as small as possible until the signal has been suitably amplified. The waveguide or cable (feeder line) between the receiving antenna and the receiver front end contributes both signal *attenuation* and thermal *noise*; the details are treated in Section 5.5.3.
19. *Receiver noise.* This is the thermal *noise* generated within the receiver; the details are treated in Sections 5.5.1 to 5.5.4.
20. *Implementation loss.* This *loss* in performance is the difference between theoretical detection performance and the actual performance due to imperfections such as timing errors, frequency offsets, finite rise and fall times of waveforms, and finite-value arithmetic.
21. *Imperfect synchronization reference.* When the carrier phase, the subcarrier phase, and the symbol timing references are all derived perfectly, the error probability is a well-defined function of E_b/N_0 discussed in Chapters 3 and 4. In general, they are not derived perfectly, resulting in a system *loss*.

5.3 RECEIVED SIGNAL POWER AND NOISE POWER

5.3.1 The Range Equation

The main purpose of the link budget is to verify that the communication system will operate according to plan—that is, the message quality (error performance) will meet the specifications. The link budget monitors the “ups” and “downs”

(gains and losses) of the transmitted signal, from its inception at the transmitter until it is ultimately received at the receiver. The compilation yields how much E_b/N_0 is received and how much safety margin exists beyond what is required. The process starts with the *range equation*, which relates power received to the distance between transmitter and receiver. We develop the range equation below.

In radio communication systems, the carrier wave is propagated from the transmitter by the use of a transmitting antenna. The transmitting antenna is a transducer that converts electronic signals into electromagnetic (EM) fields. At the receiver, a receiving antenna performs the reverse function; it converts EM fields into electronic signals. The development of the fundamental power relationship between the receiver and transmitter usually begins with the assumption of an omnidirectional RF source, transmitting uniformly over 4π steradians. Such an ideal source, called an *isotropic radiator*, is illustrated in Figure 5.3. The power density $p(d)$ on a hypothetical sphere at a distance d from the source is related to the transmitted power P_t by

$$p(d) = \frac{P_t}{4\pi d^2} \quad \text{watts/m}^2 \quad (5.1)$$

since $4\pi d^2$ is the area of the sphere. The power extracted with the receiving antenna can be written as

$$P_r = p(d)A_{er} = \frac{P_t A_{er}}{4\pi d^2} \quad (5.2)$$

where the parameter A_{er} is the absorption cross section (effective area) of the receiving antenna, defined by

$$A_{er} = \frac{\text{total power extracted}}{\text{incident power flux density}} \quad (5.3)$$

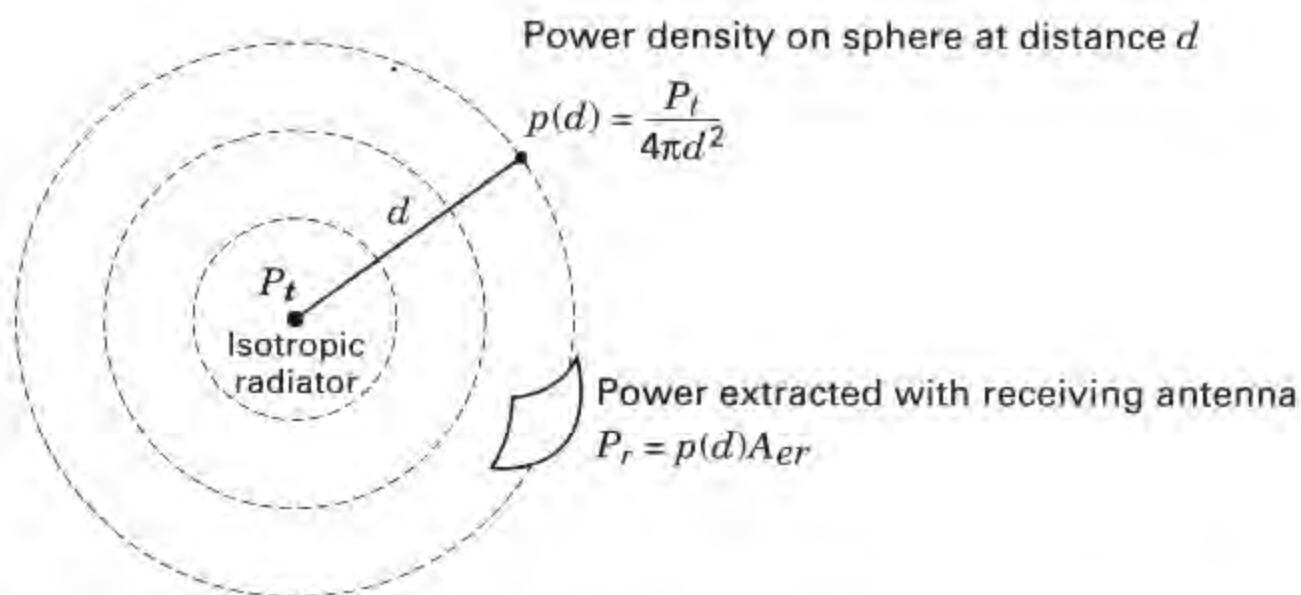

Figure 5.3 Range equation. Expresses received power in terms of distance.

If the antenna under consideration is a transmitting antenna, its effective area is designated by A_{et} . If the antenna in question is unspecified as to its receiving or transmitting function, its effective area is designated simply by A_e .

An antenna's effective area A_e and physical area A_p are related by an efficiency parameter η as

$$A_e = \eta A_p \quad (5.4)$$

which accounts for the fact that the total incident power is not extracted; it is lost through various mechanisms [3]. Nominal values for η are 0.55 for a dish (parabolic-shaped reflector) and 0.75 for a horn-shaped antenna.

The antenna parameter that relates the power output (or input) to that of an isotropic radiator as a purely geometric ratio is the antenna directivity or *directive gain*

$$G = \frac{\text{maximum power intensity}}{\text{average power intensity over } 4\pi \text{ steradians}} \quad (5.5)$$

In the absence of any dissipative loss or impedance mismatch loss, the antenna *gain* (in the direction of maximum intensity) is defined simply as the directive gain in Equation (5.5). However, in the event that there exists some dissipative or impedance mismatch loss, the antenna gain is then equal to the directive gain times a loss factor to account for these losses [4]. In this chapter we shall assume that the dissipative loss is zero and that the impedances are perfectly matched. Therefore, Equation (5.5) describes the *peak antenna gain*; it can be viewed as the result of concentrating the RF flux in some restricted region less than 4π steradians, as shown in Figure 5.4. Now we can define an *effective radiated power*, with respect to an isotropic radiator (EIRP), as the product of the transmitted power P_t and the gain of the transmitting antenna G_t , as follows:

$$\text{EIRP} = P_t G_t \quad (5.6)$$

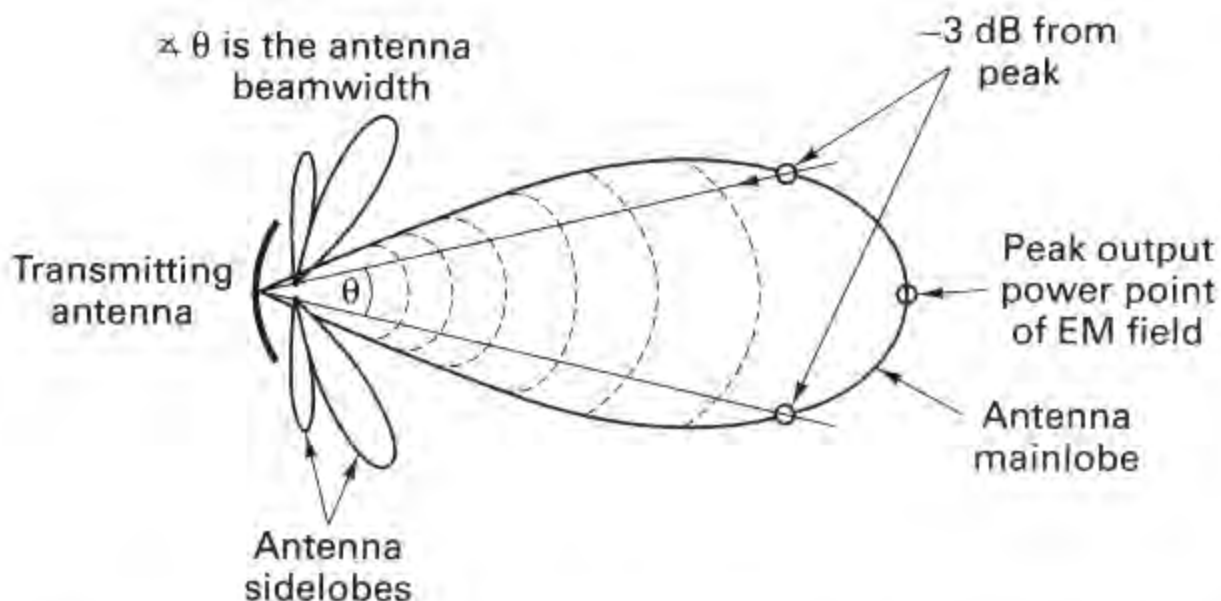

Figure 5.4 Antenna gain is the result of concentrating the isotropic RF flux.

Example 5.1 Effective Isotropic Radiated Power

Show that the same value of EIRP can be produced equally well by using a transmitter with $P_t = 100$ W or with $P_t = 0.1$ W, by employing the appropriate antenna in each case.

Solution

Figure 5.5a depicts a 100-W transmitter coupled to an isotropic antenna; the EIRP = $P_t G_t = 100 \times 1 = 100$ W. Figure 5.5b depicts a 0.1-W transmitter coupled to an antenna with gain $G_t = 1000$; the EIRP = $P_t G_t = 0.1 \times 1000 = 100$ W. If field-strength meters were positioned, as shown, to measure the effective power, the measurements could not distinguish between the two cases.

5.3.1.1 Back to the Range Equation

For the more general case in which the transmitter has some antenna gain relative to an isotropic antenna, we replace P_t with EIRP in Equation (5.2) to yield

$$P_r = \text{EIRP} \frac{A_{er}}{4\pi d^2} \tag{5.7}$$

The relationship between antenna gain G and antenna effective area A_e is [4]

$$G = \frac{4\pi A_e}{\lambda^2} \quad (\text{for } A_e \gg \lambda^2) \tag{5.8}$$

where λ is the wavelength of the carrier. Wavelength λ and frequency f are reciprocally related by $\lambda = c/f$, where c is the speed of light ($\approx 3 \times 10^8$ m/s). Similar expressions apply for both the transmitting and receiving antennas. The *reciprocity*

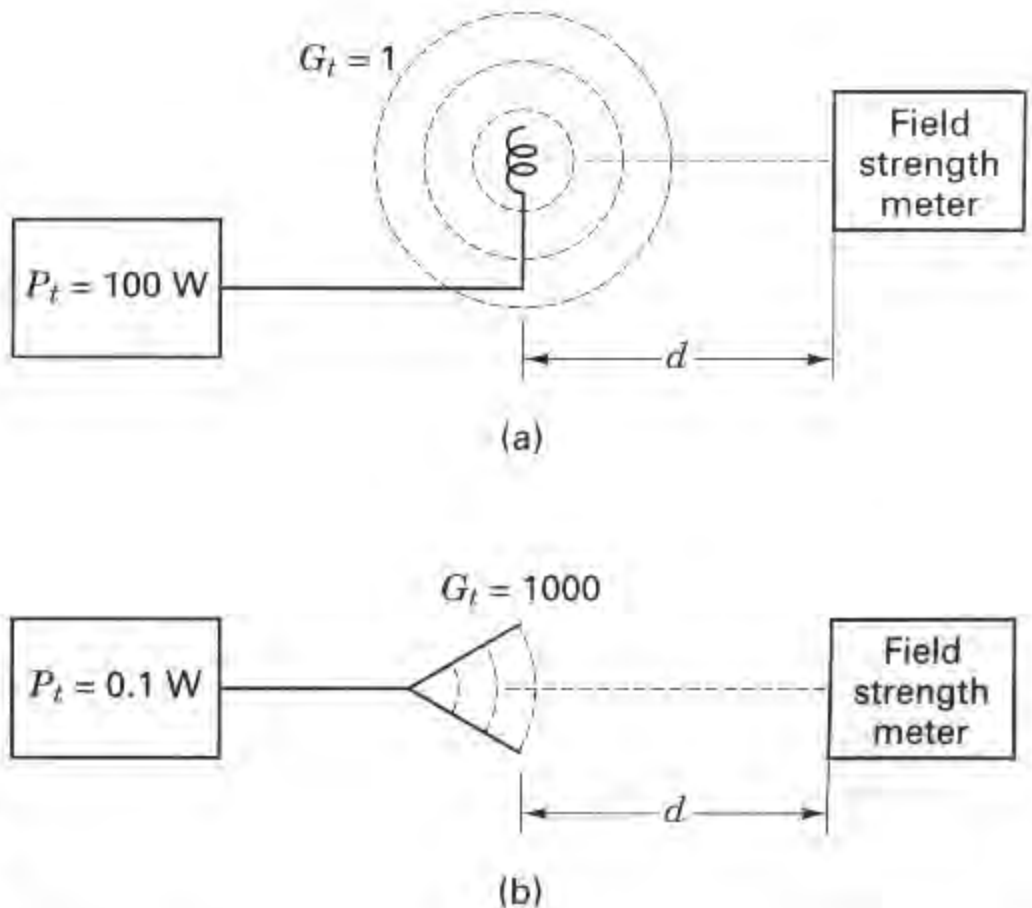

Figure 5.5 The same value of EIRP produced two different ways.

theorem states that for a given antenna and carrier wavelength, the transmitting and receiving gains are identical [4].

The antenna field of view is a measure of the solid angle into which most of the field power is concentrated. Field of view is a measure of the directional properties of the antenna; it is inversely related to antenna gain—high-gain antennas are commensurate with narrow fields of view. Instead of using the solid-angle field of view, we often deal with the planar angle *beamwidth* measured in radians or degrees. Figure 5.4 pictures a directive antenna pattern and illustrates the common definition of the antenna beamwidth. The beamwidth is the angle that subtends the points at which the peak field power is reduced by 3 dB. How does the antenna beamwidth vary with signal frequency? How does the beamwidth vary with antenna size? As can be seen from Equation (5.8), the antenna gain increases with decreased wavelength (increased frequency); antenna gain also increases with increased effective area. Increasing antenna gain is tantamount to focusing the flux density into a more restricted cone angle; hence, increasing either the signal frequency or the antenna size results in a *narrower beamwidth*.

We can calculate the effective area of an isotropic antenna by setting $G = 1$ in Equation (5.8) and solving for A_e as follows:

$$A_e = \frac{\lambda^2}{4\pi} \quad (5.9)$$

Then to find the power received, P_r , when the receiving antenna is isotropic, we substitute Equation (5.9) into Equation (5.7) to get

$$P_r = \frac{\text{EIRP}}{(4\pi d/\lambda)^2} = \frac{\text{EIRP}}{L_s} \quad (5.10)$$

where the collection of terms $(4\pi d/\lambda)^2$, called the *path loss* or *free-space loss*, is designated by L_s . Notice that Equation (5.10) states that the power received by an isotropic antenna is equal to the effective transmitted power, reduced only by the path loss. When the receiving antenna is not isotropic, replacing A_e in Equation (5.7) with $G_r\lambda^2/4\pi$ from Equation (5.8) yields the more general expression

$$P_r = \frac{\text{EIRP } G_r\lambda^2}{(4\pi d)^2} = \frac{\text{EIRP } G_r}{L_s} \quad (5.11)$$

where G_r is the receiving antenna gain. Equation (5.11) can be termed the *range equation*.

5.3.2 Received Signal Power as a Function of Frequency

Since the transmitting antenna and the receiving antenna can each be expressed as a gain or an area, P_r can be expressed four different ways:

$$P_r = \frac{P_t G_t A_{er}}{4\pi d^2} \quad (5.12)$$

$$P_r = \frac{P_t A_{et} A_{er}}{\lambda^2 d^2} \quad (5.13)$$

$$P_r = \frac{P_t A_{er} G_r}{4\pi d^2} \quad (5.14)$$

$$P_r = \frac{P_t G_t G_r \lambda^2}{(4\pi d)^2} \quad (5.15)$$

In these equations, A_{er} and A_{et} are the effective areas of the receiving and transmitting antennas, respectively.

In Equations (5.12) to (5.15) the dependent variable is received signal power, P_r , and the independent variables involve parameters such as transmitted power, antenna gain, antenna area, wavelength, and range. Suppose that we ask the question: How does received power vary as wavelength is decreased (or as frequency is increased), all other independent variables remaining constant? From Equations (5.12) and (5.14) it appears that P_r and wavelength are not related at all. From Equation (5.13), P_r appears to be inversely proportional to wavelength squared, and from Equation (5.15), P_r appears to be directly proportional to wavelength squared. Is there a paradox here? Of course there is not; Equations (5.12) to (5.15) seem to conflict only because antenna gain and antenna area are wavelength related, as stated in Equation (5.8). When should one use each of the Equations (5.12) to (5.15) for determining P_r as a function of wavelength? Consider a system that is already configured; that is, the antennas have already been built or their dimensions are fixed (A_{et} and A_{er} are fixed). Then Equation (5.13) is the appropriate choice for calculating the P_r performance. Equation (5.13) states that for fixed-size antennas, the received power increases as the wavelength is decreased.

Consider the use of Equation (5.12), where G_t and A_{er} are independent variables. We want G_t and A_{er} held fixed over the range of P_r versus wavelength calculations. What happens to the gain of a fixed-dimension transmitting antenna as the independent variable λ is decreased? G_t increases [see Equation 5.8)]. But we cannot have G_t increasing in Equation (5.12)—we want G_t held fixed. In other words, to ensure that G_t remains fixed, we would need to reduce the transmitting antenna size as wavelength decreases. It should be apparent that Equation (5.12) is the appropriate equation when starting with a *fixed transmitting antenna gain* (or beamwidth) requirement and the parameter A_{et} is not fixed. For similar reasons, Equation (5.14) is used when A_{et} and G_r are fixed, and Equation (5.15) is used when both the transmitting and receiving antenna gains (or beamwidths) are fixed.

Figure 5.6 illustrates a satellite application where the downlink antenna beam is required to provide earth coverage (a beamwidth of approximately 17° from synchronous altitude). Since the satellite antenna gain G_t must be fixed, the resulting P_r is independent of wavelength, as shown in Equation (5.12). If the transmission at some frequency f_1 ($= c/\lambda_1$) provides earth coverage, then a frequency change to f_2 , where $f_2 > f_1$, will result in reduced coverage (since for a given antenna, G_t will increase); hence the antenna size must be reduced to maintain the required earth

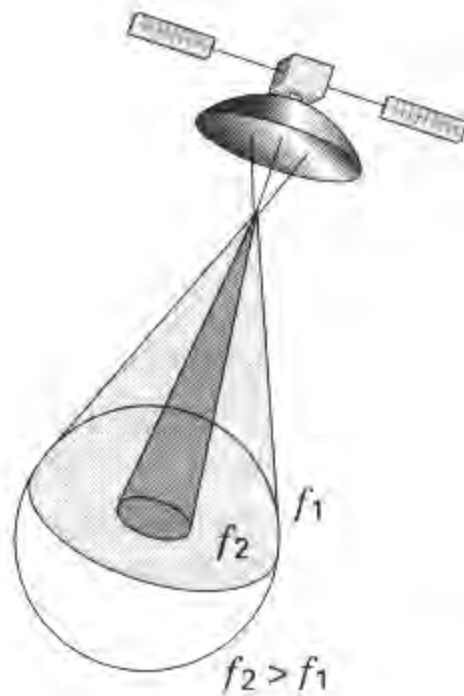

Figure 5.6 Received power as a function of frequency.

coverage or beamwidth. Thus earth coverage antennas become smaller as the carrier frequency is increased.

5.3.3 Path Loss Is Frequency Dependent

From Equation (5.10) it can be seen that path loss, L_s , is wavelength (frequency) dependent. The question is often asked: Why should path loss, which is just a geometric inverse-square loss, be a function of frequency? The answer is that path loss, as characterized in Equation (5.10), is a *definition* predicated on the use of an isotropic receiving antenna ($G_r = 1$). Hence path loss is a convenient tool; it represents a hypothetical received-power loss that *would occur if the receiving antenna were isotropic*. Figure 5.3 and Equation (5.1) have established that power density, $p(d)$, is a function of distance—a purely geometric consideration; $p(d)$ is *not* a function of frequency. However, since path loss is predicated on $G_r = 1$, when we attempt to collect some P_r with an *isotropic antenna*, the result is characterized by Equation (5.10). Again, let us emphasize that L_s can be viewed as a convenient collection of terms that have been assigned the unfortunate name *path loss*. The name conjures up an image of a purely geometric effect and fails to emphasize the requirement that $G_r = 1$. A better choice of a name would have been *unity-gain propagation loss*. In a radio communication system, path loss accounts for the largest loss in signal power. In satellite systems, the path loss for a C-band (6-GHz) link to a synchronous altitude satellite is typically 200 dB.

Example 5.2 Antenna Design for Measuring Path Loss

Design a hypothetical experiment to measure path loss L_s , at frequencies $f_1 = 30$ MHz and $f_2 = 60$ MHz, when the distance between the transmitter and receiver is 100 km. Find the effective area of the receiving antenna, and calculate the path loss in decibels for each case.

Solution

Figure 5.7 illustrates the two links for measuring L_s at frequencies f_1 and f_2 , respectively. The power density, $p(d)$, at each receiver is identical and equal to

$$p(d) = \frac{\text{EIRP}}{4\pi d^2}$$

This reduction in power density is due *only* to the inverse-square law. The actual power received at each receiver is found by multiplying the power density $p(d)$ at the receiver by the effective area, A_{er} , of the collecting antenna, as shown in Equation (5.7). Since path loss is predicated on $G_r = 1$, we compute the effective area A_{er1} at frequency f_1 , and A_{er2} at frequency f_2 , using Equation (5.9):

$$A_{er} = \frac{\lambda^2}{4\pi} = \frac{(c/f)^2}{4\pi}$$

$$A_{er1} = \frac{(3 \times 10^8 / 30 \times 10^6)^2}{4\pi} \approx 8 \text{ m}^2$$

$$A_{er2} = \frac{(3 \times 10^8 / 60 \times 10^6)^2}{4\pi} \approx 2 \text{ m}^2$$

The path loss for each case in decibels is

$$L_{s1} = 10 \times \log_{10} \left(\frac{4\pi d}{\lambda_1} \right)^2 = 10 \times \log_{10} \left(\frac{4\pi \times 10^5}{3 \times 10^8 / 30 \times 10^6} \right)^2 = 102 \text{ dB}$$

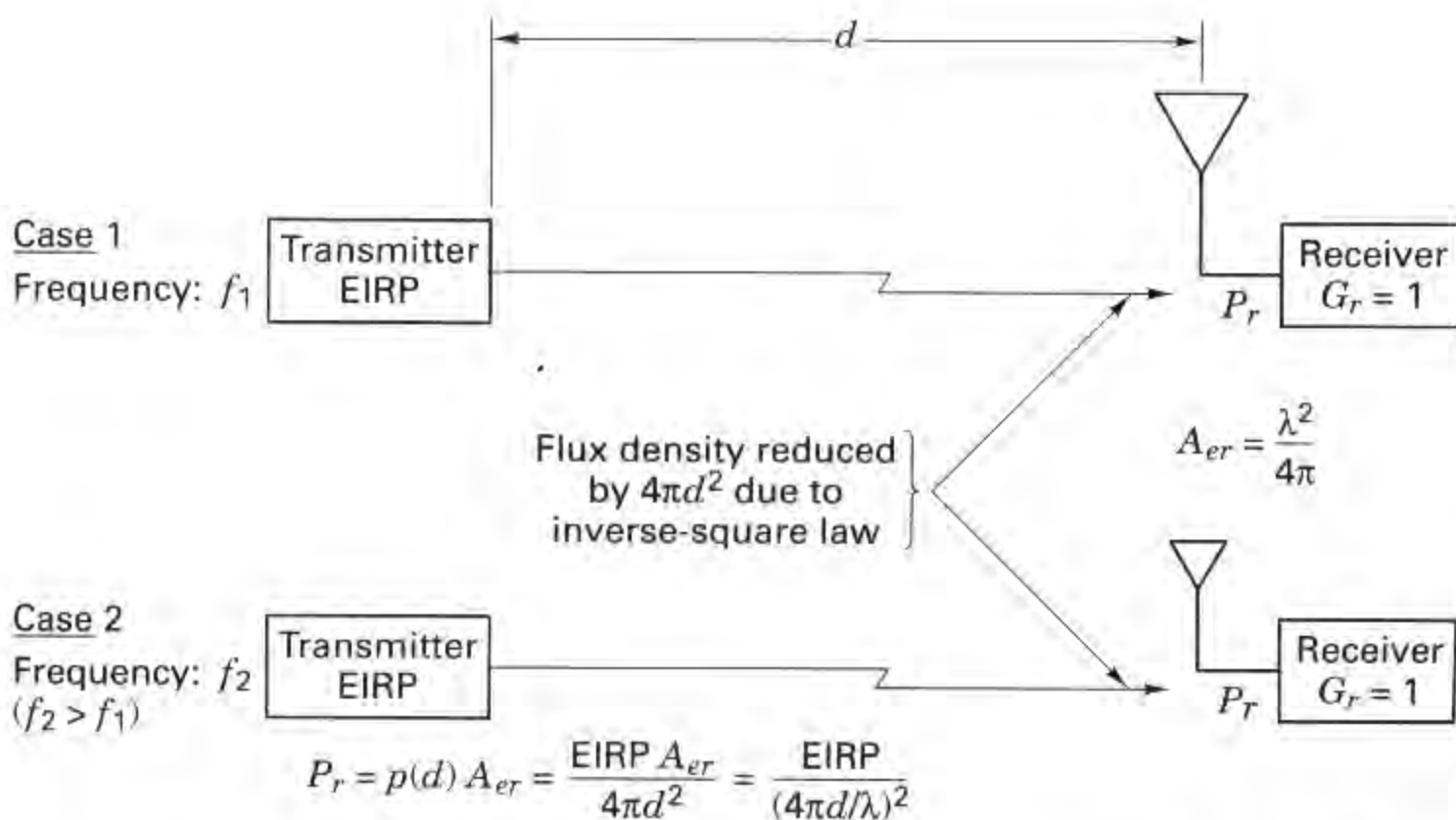

Figure 5.7 Path loss versus frequency. Hypothetical experiment to measure path loss at two different frequencies.

$$L_{\lambda_2} = 10 \times \log_{10} \left(\frac{4\pi d}{\lambda_2} \right)^2 = 10 \times \log_{10} \left(\frac{4\pi \times 10^5}{3 \times 10^8 / 60 \times 10^6} \right)^2 \\ = 108 \text{ dB}$$

5.3.4 Thermal Noise Power

Thermal noise is caused by the thermal motion of electrons in all conductors. It is generated in the lossy coupling between an antenna and receiver and in the first stages of the receiver. The noise power spectral density is constant at all frequencies up to about 10^{12} Hz, giving rise to the name *white noise*. The thermal noise process in communication receivers is modeled as an additive white Gaussian noise (AWGN) process, as described in Section 1.5.5. The physical model [5, 6] for thermal or Johnson noise is a noise generator with an open-circuit mean-square voltage of $4\kappa T^\circ W \mathcal{R}$, where

$$\kappa = \text{Boltzmann's constant} = 1.38 \times 10^{-23} \text{ J/K or W/K-Hz} \\ = -228.6 \text{ dBW/K-Hz,}$$

T° = temperature, kelvin,

W = bandwidth, hertz,

and

\mathcal{R} = resistance, ohms.

The maximum thermal noise power N that could be coupled from the noise generator into the front end of an amplifier is

$$N = \kappa T^\circ W \quad \text{watts} \quad (5.16)$$

Thus, the maximum single-sided noise power spectral density N_0 (noise power in a 1-Hz bandwidth), available at the amplifier input is

$$N_0 = \frac{N}{W} = \kappa T^\circ \quad \text{watts/hertz} \quad (5.17)$$

It might seem that the noise power should depend on the magnitude of the resistance—but it does not. Consider an intuitive argument to verify this. Electrically connect a large resistance to a small one, such that they form a closed path and such that their physical temperatures are the same. If noise power were a function of resistance, there would be a net power flow from the large resistance to the small one; the large resistance would become cooler and the small one would become warmer. This violates our experience, not to mention the second law of thermodynamics. Therefore, the power delivered from the large resistance to the small one must be equal to the power it receives.

The available power from a thermal noise source is dependent on the ambient temperature of the source (the *noise temperature*), as is seen in Equation (5.16). This leads to the useful concept of an *effective noise temperature* for noise sources

that are not necessarily thermal in origin (e.g., galactic, atmospheric, interfering signals) that can be introduced into the receiving antenna. The effective noise temperature of such a noise source is defined as the temperature of a hypothetical thermal noise source that would give rise to an equivalent amount of interfering power. The subject of noise temperature is treated in greater detail in Section 5.5.

Example 5.3 Maximum Available Noise Power

Using a noise generator with mean-square voltage equal to $4\kappa T^\circ W\mathcal{R}$, demonstrate that the maximum amount of noise power that can be coupled from this source into an amplifier is $N_i = \kappa T^\circ W$.

Solution

A theorem from network theory states that maximum power is delivered to a load when the value of the load impedance is made equal to the complex conjugate of the generator impedance [7]. In this case the generator impedance is a pure resistance, \mathcal{R} ; therefore, the condition for maximum power transfer is fulfilled when the input resistance of the amplifier equals \mathcal{R} . Figure 5.8 illustrates such a network. The input thermal noise source is represented by an electrically equivalent model consisting of a noiseless source resistor in series with an ideal voltage generator whose rms noise voltage is $\sqrt{4\kappa T^\circ W\mathcal{R}}$. The input resistance of the amplifier is made equal to \mathcal{R} . The noise voltage delivered to the amplifier input is just one-half the generator voltage, following basic circuit principles. The noise power delivered to the amplifier input can accordingly be expressed as

$$N_i = \frac{(\sqrt{4\kappa T^\circ W\mathcal{R}}/2)^2}{\mathcal{R}} = \frac{4\kappa T^\circ W\mathcal{R}}{4\mathcal{R}} = \kappa T^\circ W$$

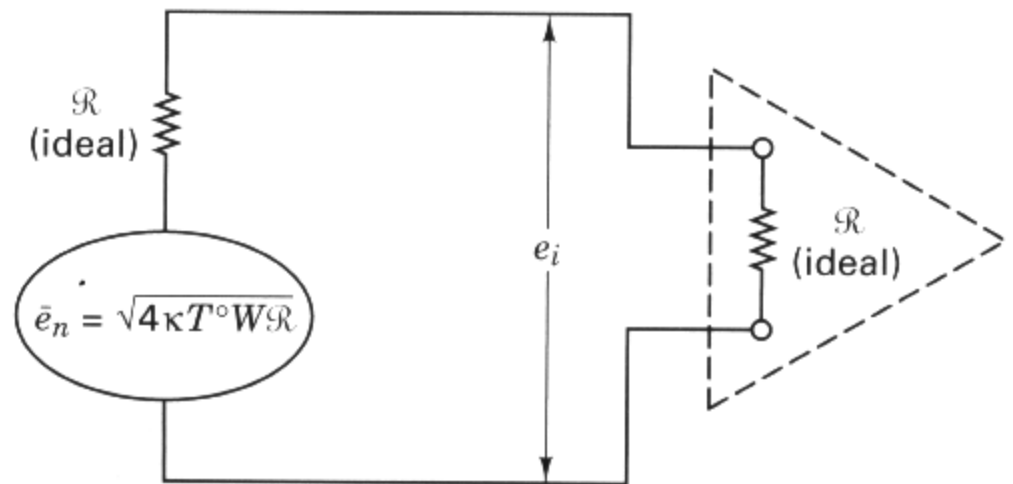

Figure 5.8 Electrical model of maximum available thermal noise power at amplifier input.

5.4 LINK BUDGET ANALYSIS

In evaluating system performance, the quantity of greatest interest is the signal-to-noise ratio (SNR) or E_b/N_0 , since a major concern is the ability to detect signals in the presence of noise with an acceptable error probability. Since in the case of satellite communication systems, the most usual signal structure is a modulated carrier with constant envelope, we can use average carrier power-to-noise power (C/N)

ratio as the predetection SNR of interest. In fact, for constant-envelope signaling, the predetection SNR is often expressed by using any of the equivalent ratio terms

$$\frac{P_r}{N} \equiv \frac{S}{N} \equiv \frac{C}{N} \equiv \frac{C}{kT^\circ W}$$

where P_r , S , C , and N are received power, signal power, carrier power, and noise power, respectively. And, k , T° , and W are Boltzmann's constant, temperature in Kelvin, and bandwidth, respectively. Is P_r/N or S/N actually the same as carrier-to-noise (C/N) at all times? No, the signal power and the carrier power are only the same for the case of constant envelope signaling (angle modulation). For example, consider a frequency modulated (FM) carrier wave expressed in terms of the modulating message waveform $m(t)$ as

$$s(t) = A \cos(\omega_0 t + K \int m(t) dt)$$

where K is a constant of the system. The average power in the modulating signal is $\overline{m^2(t)}$. Increasing this modulating power only serves to increase the frequency deviation of $s(t)$, which means that the carrier is spread over a wider spectrum, but its average power $\overline{s^2(t)}$ remains equal to $A^2/2$, regardless of the power in the modulating signal. Thus, we can see that FM, which is an example of constant-envelope signaling, is characterized by the fact that the received signal power is the same as the carrier power.

For linear modulation, such as amplitude modulation (AM), the power in the carrier is quite different than the power in the modulating signal. For example, consider an AM carrier wave in terms of the modulating signal $m(t)$:

$$\begin{aligned} s(t) &= [1 + m(t)] A \cos \omega_0 t \\ \overline{s^2(t)} &= [1 + m(t)]^2 \frac{A^2}{2} \\ &= \frac{A^2}{2} [1 + \overline{m^2(t)} + 2\overline{m(t)}] \end{aligned}$$

If we assume that $m(t)$ has a zero mean, then the average carrier power can be written as

$$\overline{s^2(t)} = \frac{A^2}{2} + \frac{A^2}{2} \overline{m^2(t)}$$

From the above expression, it should be clear that in this case the power in the carrier wave is not the same as the signal power. In summary, the parameters C/N and P_r/N are the same for constant-envelope signaling (e.g., PSK or FSK) but are different for nonconstant-envelope signaling (e.g., ASK, QAM).

We obtain P_r/N by dividing Equation (5.11) by noise power N , as follows:

$$\frac{P_r}{N} = \frac{\text{EIRP } G_r/N}{L_s} \quad (5.18)$$

Equation (5.18) applies to any one-way RF link. With *analog receivers*, the noise bandwidth (generally referred to as the effective or equivalent noise bandwidth) seen by the demodulator is usually greater than the signal bandwidth, and P_r/N is the main parameter for measuring signal detectability and performance quality. With *digital receivers*, however, correlators or matched filters are usually implemented, and signal bandwidth is taken to be equal to noise bandwidth. Rather than consider input noise power, a common formulation for digital links is to replace noise power with *noise power spectral density*. We can use Equation (5.17) to rewrite Equation (5.18) as

$$\frac{P_r}{N_0} = \frac{\text{EIRP } G_r/T^\circ}{\kappa L_s L_o} \quad (5.19)$$

where the system effective temperature T° is a function of the noise radiated into the antenna and the thermal noise generated within the first stages of the receiver. Note that the receiving antenna gain G_r and system temperature T° are grouped together. The grouping G_r/T° is sometimes called the *receiver figure-of-merit*. The reason for treating these terms in this way is explained in Section 5.6.2.

It is important to emphasize that the effective temperature T° is a parameter that *models* the effect of various noise sources; the subject is treated in greater detail in Section 5.5. In Equation (5.19) we have introduced a term L_o to represent all other losses and degradation factors not specifically addressed by the other terms of Equation (5.18). The factor L_o allows for the large assortment of different losses and noise sources cataloged earlier. Equation (5.19) summarizes the key parameters of any link analysis: the received signal power-to-noise power spectral density (P_r/N_0), the effective transmitted power (EIRP), the receiver figure-of-merit (G_r/T°), and the losses (L_s, L_o). We are developing a methodical way to keep track of the gains and losses in a communications link. By starting with some source of power we can compute, using Equation (5.19), the net SNR arriving at the “face” of the detector (predetection point). We are working toward a “bookkeeping” system, much like the type used in a business that earmarks assets and liabilities and tallies up the bottom-line of profit (or loss). Equation (5.19) takes on such an entrepreneurial appearance. All of the numerator parameters (effective radiated power, receiver figure-of-merit) are like the assets of a business, and all the denominator parameters (thermal noise, space loss, other losses) are like the liabilities of a business.

Assuming that all the received power P_r is in the modulating (information-bearing) signal, we now relate E_b/N_0 and SNR from Equation (3.30) and write

$$\frac{E_b}{N_0} = \frac{P_r}{N} \left(\frac{W}{R} \right) \quad (5.20a)$$

$$\frac{E_b}{N_0} = \frac{P_r}{N_0} \left(\frac{1}{R} \right) \quad (5.20b)$$

and

$$\frac{P_r}{N_0} = \frac{E_b}{N_0} R \quad (5.20c)$$

where R is the bit rate. If some of the received power is carrier power (a signal-power loss), we can still employ Equation (5.20), except that the carrier power contributes to the loss factor, L_o in Equation (5.19). This fundamental relationship between E_b/N_0 and P_r/N_0 in Equation (5.20) will be required frequently in designing and evaluating systems. (See Chapter 9.)

5.4.1 Two E_b/N_0 Values of Interest

We have referred to E_b/N_0 as that value of bit energy per noise power spectral density required to yield a specified error probability. To facilitate calculating a margin or safety factor M , we need to differentiate between the *required* E_b/N_0 and the actual or *received* E_b/N_0 . From this point on we will refer to the former as $(E_b/N_0)_{\text{reqd}}$ and to the latter as $(E_b/N_0)_r$. Figure 5.9 depicts an example with two operating points. The first is associated with $P_B = 10^{-3}$; let us call this operating point the system required error performance. Let us assume that an $(E_b/N_0)_{\text{reqd}}$ value of 10 dB will yield this required performance. Do you suppose we would build this system so that the demodulator received this 10-dB value *exactly*? Of course not; we would specify and design the system to have a safety margin, so that the $(E_b/N_0)_r$ actually received would be somewhat larger than the $(E_b/N_0)_{\text{reqd}}$. Thus we might design the system to operate at the second operating point on Figure 5.9; here $(E_b/N_0)_r = 12$ dB and $P_B = 10^{-5}$. For this example we can describe the safety margin or *link margin*, as providing a two-order-of-magnitude improved P_B , or as is more usual, we can describe the link margin in terms of providing 2 dB more E_b/N_0

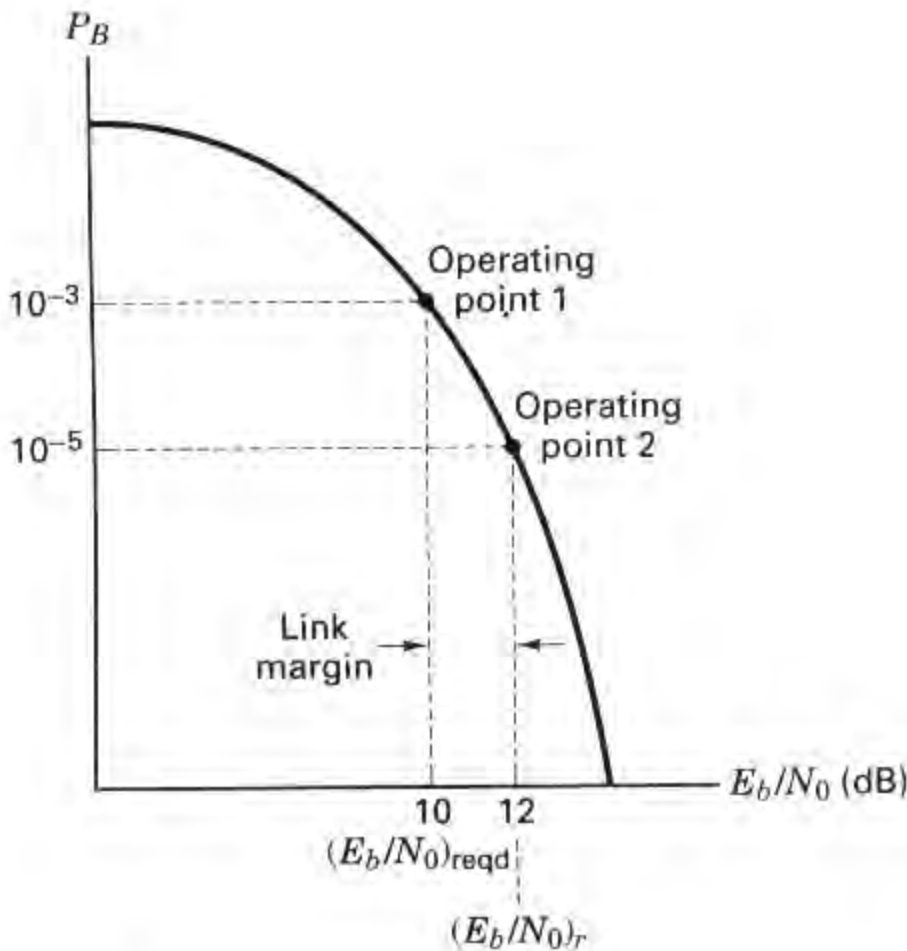

Figure 5.9 Two E_b/N_0 values of interest.

than is required. We can rewrite Equation (5.20c), introducing the link margin parameter M as

$$\frac{P_r}{N_0} = \left(\frac{E_b}{N_0}\right)_r \quad R = M \left(\frac{E_b}{N_0}\right)_{\text{reqd}} R \quad (5.21)$$

The difference in decibels between $(E_b/N_0)_r$ and $(E_b/N_0)_{\text{reqd}}$ yields the link margin:

$$M(\text{dB}) = \left(\frac{E_b}{N_0}\right)_r (\text{dB}) - \left(\frac{E_b}{N_0}\right)_{\text{reqd}} (\text{dB}) \quad (5.22)$$

The parameter $(E_b/N_0)_{\text{reqd}}$ reflects the differences from one system design to another; these might be due to differences in modulation or coding schemes. A larger than expected $(E_b/N_0)_{\text{reqd}}$ may be due to a suboptimal RF system, which manifests large timing errors or which allows more noise into the detection process than does an ideal matched filter.

Combining Equations (5.19) and (5.21) and solving for the link margin M yields

$$M = \frac{\text{EIRP } G_r / T^\circ}{(E_b/N_0)_{\text{reqd}} R \kappa L_s L_o} \quad (5.23)$$

Equation (5.23), the *link margin equation*, contains all of the parameters contributing to the link's error performance. Some of these parameters are defined with reference to particular locations. For example, E_b/N_0 is defined at the input to the receiver. More precisely, it is defined at the input to the detector (predetection point), where a demodulated waveform having a voltage amplitude proportional to received energy is the basis of a symbol decision. Similarly, any parameter describing received energy or power, whether useful or degrading, is also defined with reference to this predetection point. The receiver's figure-of-merit G_r/T° is defined at the input to the receiving antenna, where G_r is the gain of the receiving antenna, and T° is the effective system temperature. (See Section 5.5.5.) The effective radiated power EIRP is defined as the power associated with the electromagnetic wave at the output of the transmitting antenna. Each of these parameters, E_b/N_0 , G_r/T° , and EIRP is defined with reference to a particular system location, and nowhere else.

5.4.2 Link Budgets Are Typically Calculated in Decibels

Since link budget analysis is typically calculated in decibels, we can express Equation (5.23) as

$$\begin{aligned} M(\text{dB}) = & \text{EIRP (dBW)} + G_r (\text{dBi}) - \left(\frac{E_b}{N_0}\right)_{\text{reqd}} (\text{dB}) - R (\text{dB-bit/s}) \\ & - \kappa T^\circ (\text{dBW/Hz}) - L_s (\text{dB}) - L_o (\text{dB}) \end{aligned} \quad (5.24)$$

Transmitted signal power EIRP is expressed in decibel-watts (dBW); noise power spectral density N_0 is in decibel-watts per hertz (dBW/Hz); antenna gain G_r is in decibels referenced to isotropic gain (dBi); data rate R is in decibels referenced to

1 bit/s (dB-bit/s); and all other terms are in decibels (dB). The numerical values of the Equation (5.24) parameters constitute the link budget, a useful tool for allocating communications resources. In an effort to maintain a positive margin, we might trade off any parameter with any other parameter; we might choose to reduce transmitter power by giving up excess margin, or we might elect to increase the data rate by reducing $(E_b/N_0)_{\text{reqd}}$ (through the selection of improved modulation and coding). Any one of the Equation (5.24) decibels, regardless of the parameter from which it stems, is just as good as any other decibel—a dB is a dB is a dB. The transmission system “does not know and does not care” where the decibels come from. As long as the needed amount of E_b/N_0 arrives at the receiver, the desired system error performance can be met. Well, let us add two other conditions for achieving a required error performance—synchronization must be maintained, and ISI distortion must be minimized or equalized. One might ask, Since the system has no preference as to where the decibels of E_b/N_0 come from, how shall we prioritize the search for an adequate number of decibels? The answer is, we should look for the most cost-effective decibels. This goal will steer us toward reading the next several chapters on error-correction coding, since this discipline has historically provided a continual reduction in the cost of electronics to achieve error-performance improvements.

5.4.3 How Much Link Margin Is Enough?

The question of how much link margin should be designed into a system is asked frequently. The answer is that if all sources of gain, loss, and noise have been rigorously detailed (worst case), and if the link parameters with large variances (e.g., fades due to weather) match the statistical requirements for link availability, very little additional margin is needed. The margin needed depends on how much confidence one has in each of the link budget entries. For systems employing new technology or new operating frequencies, one needs more margin than for systems that have been repeatedly built and tested. Sometimes the link budget provides an allowance for fades due to weather directly, as a line item. Other times, however, the required value of margin reflects the link requirements for a given rain degradation. For satellite communications at C-band (uplink at 6 GHz, downlink at 4 GHz), where the parameters are well known and fairly well behaved, it should be possible to design a system with only 1 dB of link margin. Receive-only television stations operating with 16-ft-diameter dishes at C-band are frequently designed with only a fraction of a decibel of margin. However, telephone communications via satellite using standards of 99.9% availability require considerably more margin; some of the INTELSAT systems have 4 to 5 dB of margin. When nominal rather than worst-case computations are performed, allowances are usually made for unit-to-unit equipment variations over the operating temperature range, line voltage variations, and mission duration. Also, for space communications, there may be an allowance for errors in tracking a satellite's location.

Designs using higher frequencies (e.g., 14/12 GHz) generally call for larger (weather) margins because atmospheric losses increase with frequency and are highly variable. It should be noted that a by-product of the attenuation due to atmospheric loss is greater antenna noise. With low-noise amplifiers, small weather

changes can result in increases of 40 to 50 K in antenna temperature. Table 5.1 represents a link analysis proposed to the Federal Communications Commission (FCC) by Satellite Television Corporation for the Direct Broadcast Satellite (DBS) service. Notice that the downlink budget is tabulated for two alternative weather conditions: clear, and 5-dB loss due to rain. The signal loss due to atmospheric attenuation is only a small fraction of a decibel for clear weather and is the full 5 dB during rain. The next item in the downlink tabulation, home receiver G/T° , illustrates the additional degradation caused by the rain; additional thermal noise irradiates the receiving antenna, making the effective system noise temperature, T° , increase, and the home receiver G/T° decrease (from 9.4 dB/K to 8.1 dB/K). Therefore, when extra margin is allowed for weather loss, additional margin should simultaneously be added to compensate for the increase in system noise temperature.

With regard to satellite links, in industry one often hears such expressions as “the link *can* be closed,” meaning that the margin, in decibels, has a positive value and the required error performance will be satisfied, or “the link *cannot* be closed,” meaning that the margin has a negative value and the required error performance will *not* be satisfied. Even though the words “the link closes” or “the link does not close” give the impression of an “on-off” condition, it is worth emphasizing that lack of link closure, or a negative margin, means that the error performance falls short of the system requirement; it does not necessarily mean that communications cease. For example, consider a system whose $(E_b/N_0)_{\text{reqd}} = 10$ dB, as shown in Figure 5.9, but whose $(E_b/N_0)_r = 8$ dB. Assume that 8 dB corresponds to $P_B = 10^{-2}$.

TABLE 5.1 Proposed Direct Broadcast Satellite (DBS) from Satellite Television Corp.

Uplink		Atmospheric Condition	
Downlink	Clear	5-dB Rain Attenuation	
Earth station EIRP	86.6 dBW	57.0 dBW	
Free-space loss (17.6 GHz, 48° elevation)	208.9 dB	206.1 dB	
Assumed rain attenuation	12.0 dB	0.14 dB	
Satellite G/T°	7.7 dB/K	9.4 dB/K	
Uplink $C/\kappa T^\circ$	102.0 dB-Hz	0.6 dB	
		0.04 dB	
Satellite EIRP	57.0 dBW	57.0 dBW	
Free-space loss (12.5 GHz, 30° elevation)	206.1 dB	206.1 dB	
Atmospheric attenuation	0.14 dB	5.0 dB	
Home receiver G/T° (0.75 m dish)	9.4 dB/K	8.1 dB/K	
Receiver pointing loss (0.5° error)	0.6 dB	0.6 dB	
Polarization mismatch loss (average)	0.04 dB	0.04 dB	
Downlink $C/\kappa T^\circ$	88.1 dB-Hz	82.0 dB-Hz	
Overall $C/\kappa T^\circ$	87.9 dB-Hz	82.0 dB-Hz	
Overall C/N (in 16 MHz)	15.9 dB	10.0 dB	
Reference threshold C/N	10.0 dB	10.0 dB	
Margin over threshold	5.9 dB	0.0 dB	

Thus there is a margin of -2 dB, and a bit error probability of 10 times the specified error probability. The link may still be useful, though degraded.

5.4.4 Link Availability

Link availability is usually a measure of long-term link utility stated on an average annual basis; for a given geographical location, the link availability measures the percentage of time the link can be closed. For example, for a particular link between Washington, D.C., and a satellite repeater, the long-term weather pattern may be such that a 10-dB weather margin is adequate for link closure 98% of the time; for 2% of the time, heavy rains result in greater than 10 dB SNR degradation, so that the link does not close. Since the effect of rain on SNR degradation is a function of signal frequency, link availability and required margin must be examined in the context of a particular transmission frequency.

Figure 5.10 summarizes worldwide satellite link availability at a frequency of 44 GHz. The plot illustrates percentage of the earth visible (the link closes, and a prescribed probability of error is met) as a function of margin for the case of three equispaced geostationary satellites. A *geostationary satellite* is located in a circular orbit in the same plane as the earth's equatorial plane and at the synchronous altitude of 35,800 km. The satellite's orbital period is identical with that of the earth's rotational period, and therefore the satellite appears stationary when viewed from the earth. Figure 5.10 shows a family of visibility curves with different required link availabilities, ranging from benign (95% availability) to fairly stringent (99% availability). In general, for a fixed link margin, visibility is inversely proportional to required availability, and for a fixed availability, visibility increases monotonically with margin [8]. Figures 5.11 to 5.13 illustrate, by

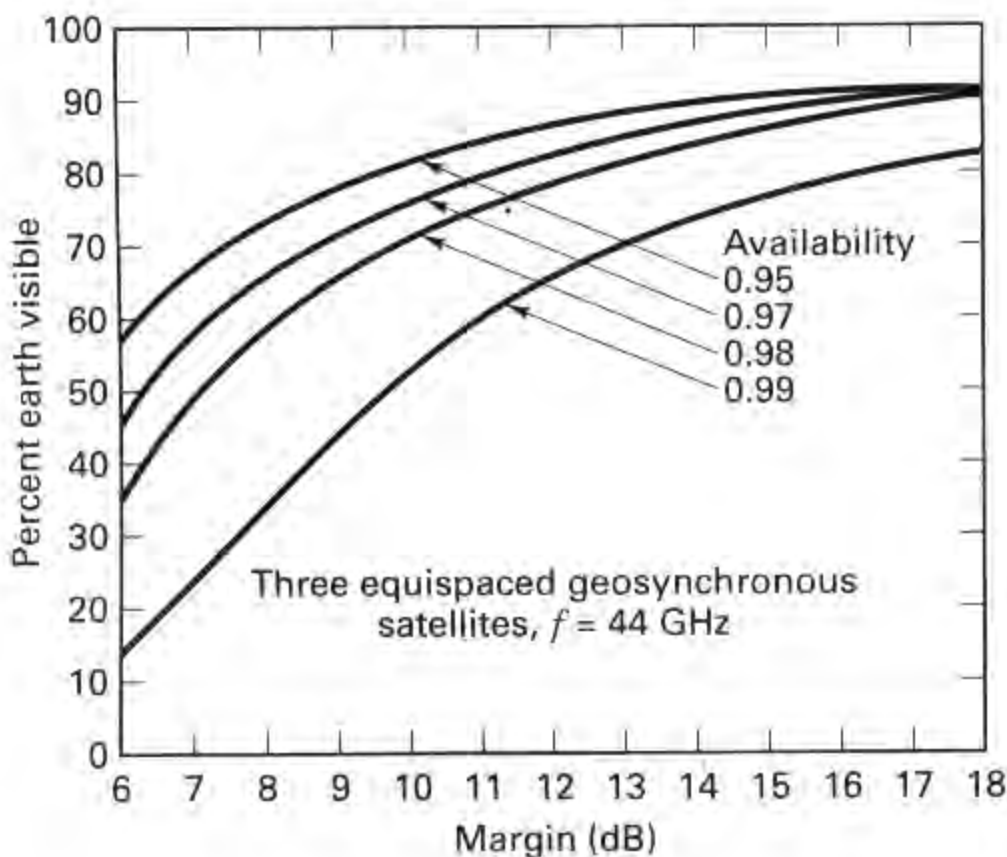

Figure 5.10 Earth coverage versus link margin for various values of link availability. (Reprinted from L. M. Schwab, "World-Wide Link Availability for Geostationary and Critically Inclined Orbits Including Rain Effects," *Lincoln Laboratory, Rep. DCA-9*, Jan. 27, 1981, Fig. 14, p. 38, courtesy of Lincoln Laboratory.)

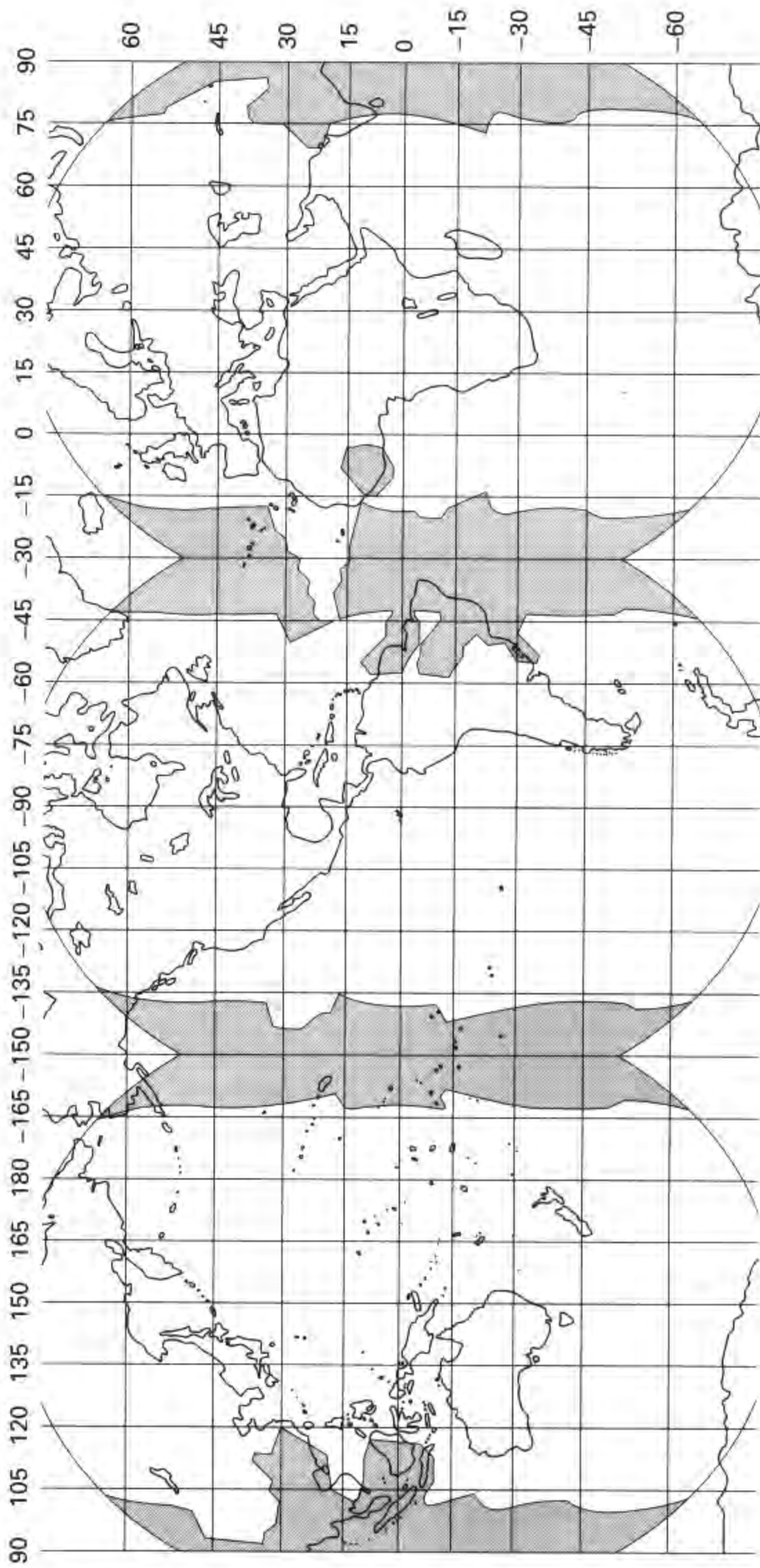

Figure 5.11 Earth coverage (unshaded) for 0.99 link availability for three equispaced geostationary satellites, $f = 44$ GHz, link margin = 14 dB. (Reprinted from L. M. Schwab, "World-Wide Link Availability for Geostationary and Critically Inclined Orbits Including Rain Effects," *Lincoln Laboratory, Rep. DCA-9*, Jan. 27, 1981, Fig. 17, p. 42, courtesy of Lincoln Laboratory.)

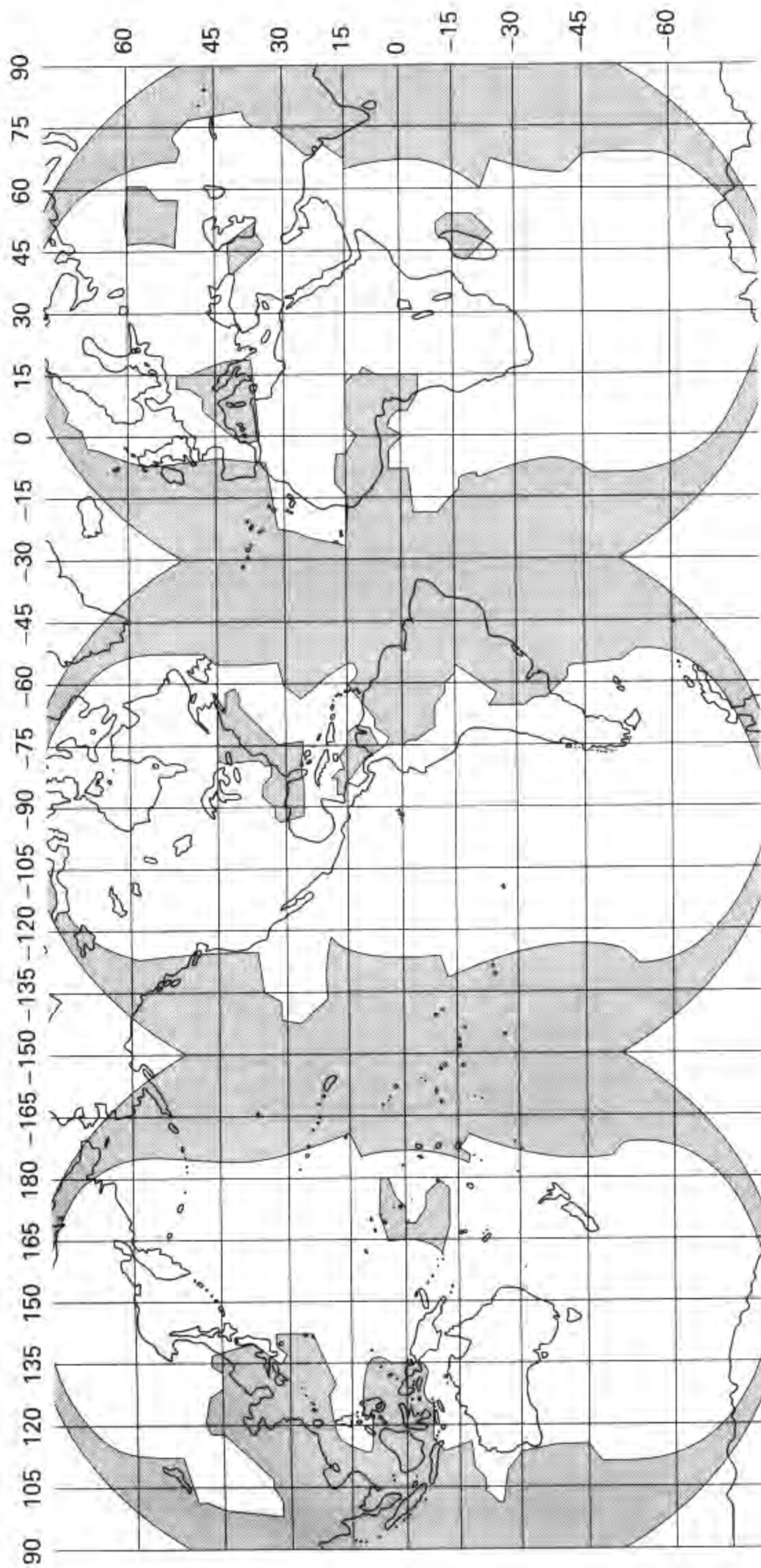

Figure 5.12 Earth coverage (unshaded) for 0.99 link availability for three equispaced geostationary satellites, $f = 44$ GHz, link margin = 10 dB. (Reprinted from L. M. Schwab, "World-Wide Link Availability for Geostationary and Critically Inclined Orbits Including Rain Effects," *Lincoln Laboratory, Rep. DCA-9*, Jan. 27, 1981, Fig. 18, p. 43, courtesy of Lincoln Laboratory.)

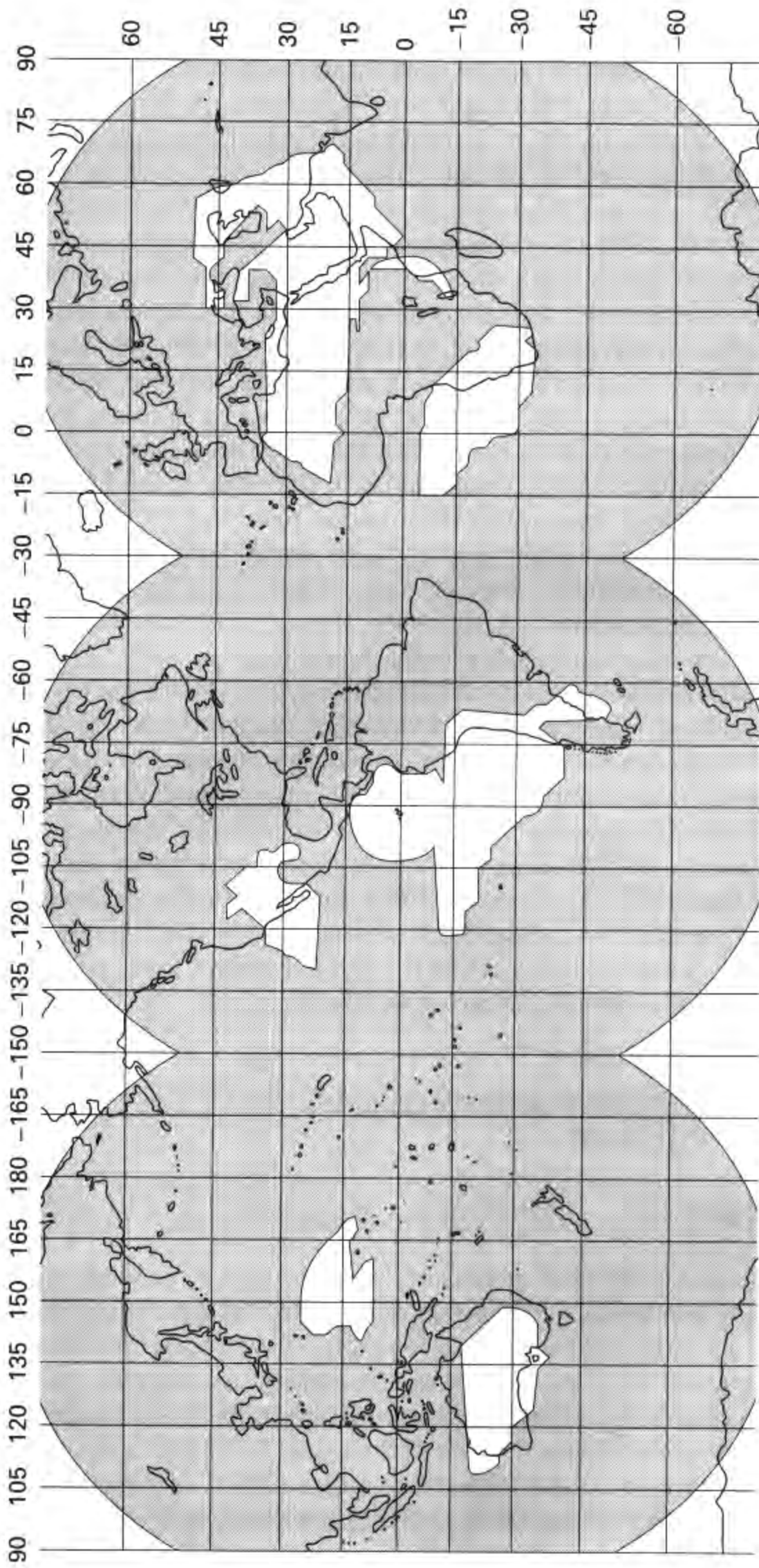

Figure 5.13 Earth coverage (unshaded) for 0.99 link availability for three equispaced geostationary satellites, $f = 44$ GHz, link margin = 6 dB. (Reprinted from L. M. Schwab, "World-Wide Link Availability for Geostationary and Critically Inclined Orbits Including Rain Effects," *Lincoln Laboratory, Rep. DCA-9*, Jan. 27, 1981, Fig. 19, p. 44, courtesy of Lincoln Laboratory.)

unshaded and shaded areas, the parts of the earth from which the 44-GHz link can and cannot be closed 99% of the time for three different values of link margin. Figure 5.11 illustrates the link coverage of such locations for a margin value of 14 dB. Notice that this figure can be used to pinpoint the regions of heaviest rainfall, such as Brazil and Indonesia. The figure represents the result of a link calculation performed in concert with a weather model of the earth.

In Figure 5.11 there are shaded strips on the east and west boundaries of each satellite's field of view. Why do you suppose the link availability is not met in these regions? At the edge of the earth the propagation path between the satellite and ground is longer than the path directly beneath the satellite. Degradation occurs in three ways: (1) the longer path results in reduced power density at the receiving antenna; (2) the edge of coverage sites will experience reduced satellite antenna gain, unless the satellite antenna pattern is designed to be uniform over its entire field of view (typically the pattern is -3 dB at the beam edge compared to the peak gain at the beam center); and (3) propagation to the edge of the earth traverses a thicker atmospheric layer because of the oblique path and the earth's curvature. The third item is of prime importance at those signal frequencies that are most attenuated by the atmosphere. Why do you suppose you do not see the same shaded areas near the north and south poles in Figure 5.11? Snowfall does not have the same deleterious effect on signal propagation as does rainfall; the phenomenon is known as the *freeze effect*.

Figure 5.12 illustrates the parts of the earth that can and cannot close the 44-GHz link 99% of the time with 10-dB link margin. Notice that the shaded areas have grown considerably compared to the 14-dB margin case; now, the east coast of the United States, the Mediterranean, and most of Japan cannot close the link 99% of the time. Figure 5.13 illustrates similar link performance for a margin of 6 dB. Whereas Figure 5.11 could be used to locate the regions of greatest rainfall, Figure 5.13 can be used to locate the driest weather regions on the earth; such areas are seen to be the southwestern part of the United States, most of Australia, the coast of Peru and Chile, and the Sahara desert in Africa.

5.5 NOISE FIGURE, NOISE TEMPERATURE, AND SYSTEM TEMPERATURE

5.5.1 Noise Figure

Noise figure, F , relates the SNR at the input of a network to the SNR at the output of the network. Thus noise figure measures the SNR degradation caused by the network. Figure 5.14 illustrates such an example. Figure 5.14a depicts the SNR at an *amplifier input* $(\text{SNR})_{\text{in}}$ as a function of frequency. At its peak, the signal is 40 dB above the noise floor. Figure 5.14b depicts the SNR at the *amplifier output* $(\text{SNR})_{\text{out}}$. The amplifier gain has increased the signal by 20 dB; however, the amplifier has added its own additional noise. The output signal, at its peak, is only 30 dB above the noise floor. Since the SNR degradation from input to output is 10 dB,

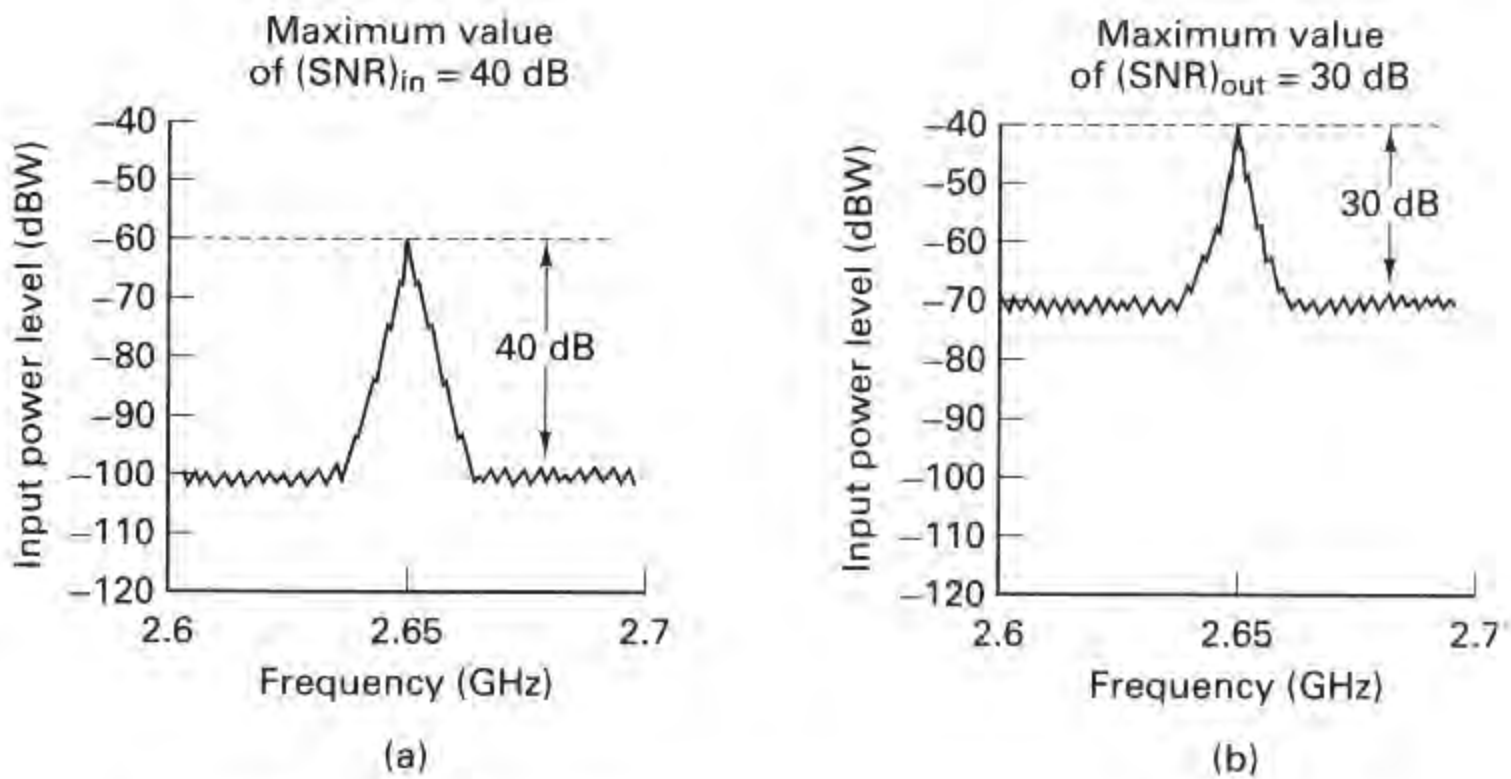

Figure 5.14 Amplifier signal and noise levels as a function of frequency. (a) Amplifier input. (b) Amplifier output.

this is tantamount to describing the amplifier as having a 10-dB noise figure. Noise figure is a parameter that expresses the noisiness of a two-port network or device, such as an amplifier, compared with a reference noise source at the input port. It can be written as

$$F = \frac{(\text{SNR})_{\text{in}}}{(\text{SNR})_{\text{out}}} = \frac{S_i/N_i}{GS_i/G(N_i + N_{ai})} \quad (5.25)$$

where

S_i = signal power at the amplifier input port,

N_i = noise power at the amplifier input port,

N_{ai} = amplifier noise referred to the input port,

and

G = amplifier gain.

Figure 5.15 is an example illustrating Equation (5.25). Figure 5.15a represents a *realizable amplifier* example with a gain $G = 100$, and internal noise power $N_a = 10 \mu\text{W}$. The source noise, external to the amplifier, is $N_i = 1 \mu\text{W}$. In Figure 5.15b we assume that the *amplifier is ideal*, and we ascribe the noisiness of the real amplifier, from part (a) of the figure, to an external source N_{ai} in series with the original source N_i . The value of N_{ai} is obtained by reducing N_a by the amplifier gain. As shown in Figure 5.15b, Equation (5.25) references all noise to the amplifier input, whether the noise is actually present at the input or is internal to the device. As can

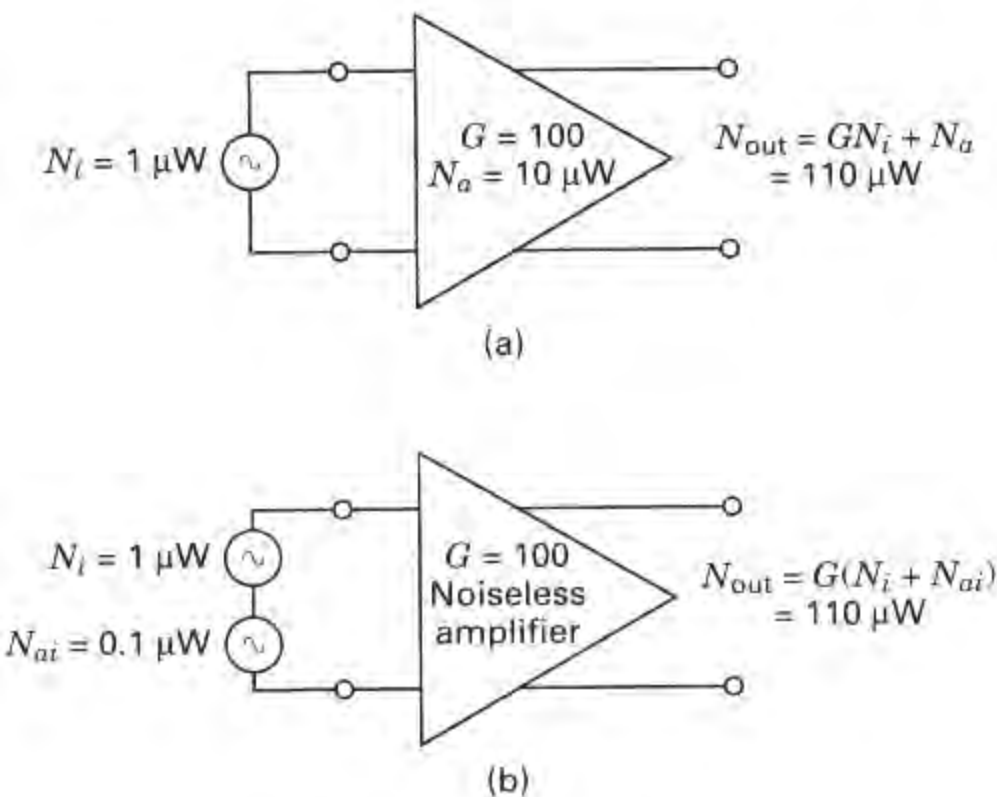

Figure 5.15 Example of noise treatment in amplifiers.

be seen in Figure 5.15, the noise power output from the real amplifier is identical to that of its electrically equivalent model.

Equation (5.25) reduces to

$$F = \frac{N_i + N_{ai}}{N_i} = 1 + \frac{N_{ai}}{N_i} \quad (5.26)$$

Notice from Equation (5.26) that the noise figure expresses the noisiness of a network relative to an input source noise; noise figure is *not* an absolute measure of noise. An ideal amplifier or network, one that contributes no noise ($N_{ai} = 0$), has a noise figure equal to unity (0 dB).

For the concept of noise figure to have utility, we need to be able to make equitable comparisons among devices on the basis of Equation (5.26). We must, therefore, choose a value of N_i as a *reference*. The noise figure of any device will then represent a measure of how much noisier the device is than the reference. In 1944, Friis [9] suggested that noise figure be defined for a noise source at a reference temperature of $T_0^\circ = 290$ K. That suggestion was subsequently adopted by the IEEE as part of its standard definition for noise figure [10]. From Equation (5.17) we see that the maximum available noise power spectral density from any source resistance is established by specifying its temperature. The value of 290 K was selected as the reference because it is a reasonable approximation of the source temperature for many links. Also, with T_0° chosen to be 290 K, the value of noise spectral density N_0 at T_0° results in an aesthetically pleasing number:

$$N_0 = \kappa T_0^\circ = 1.38 \times 10^{-23} \times 290 = 4.00 \times 10^{-21} \text{ W/Hz}$$

Or, expressed in decibels,

$$N_0 = -204 \text{ dBW/Hz}$$

Now that noise figure F has been defined with reference to a 290 K noise source, it is important to emphasize that the noise figure relationships in Equations (5.25) and (5.26) are only accurate when N_i is a 290 K noise source. For those cases where N_i is other than 290 K, we must rename F in Equations (5.25) and (5.26) to be termed *operational noise figure* F_{op} . The relationship between F_{op} and F is shown later in Equation (5.48).

5.5.2 Noise Temperature

Rearranging Equation (5.26), we can write

$$N_{ai} = (F - 1)N_i \quad (5.27)$$

From Equation (5.16) we can replace N_i with $\kappa T_0^\circ W$ and N_{ai} with $\kappa T_R^\circ W$, where T_0° is the reference temperature of the source and T_R° is called the *effective noise temperature* of the receiver (or network). We can then write

$$\kappa T_R^\circ W = (F - 1)\kappa T_0^\circ W$$

or

$$T_R^\circ = (F - 1) T_0^\circ$$

Or, since T_0° has been chosen to be 290 K,

$$T_R^\circ = (F - 1)290 \text{ K} \quad (5.28)$$

Equation (5.26) uses the concept of noise figure to characterize the noisiness of an amplifier. Equation (5.28) represents an alternative but equivalent characterization known as *effective noise temperature*. Note that the noise figure is a measurement relative to a reference. However, noise temperature has no such constraint.

We can think of available noise power spectral density and effective noise temperature, in the context of Equation (5.17), as equivalent ways of characterizing noise sources. Equation (5.28) tells us that the noisiness of an amplifier can be modeled as if it were caused by an additional noise source, as seen in Figure 5.15b, operating at some effective temperature called T_R° . For a purely resistive termination, T_R° is never less than ambient temperature unless it is cooled. It is important to note that for reactive terminations, such as uncooled parametric amplifiers or other low-noise devices, T_R° can be much less than 290 K, even though the ambient temperature is higher [11]. For the output of an amplifier as a function of its effective temperature, we can use Equations (5.16), (5.25), and (5.28) to write

$$N_{out} = GN_i + GN_{ai} \quad (5.29a)$$

$$= G\kappa T_g^\circ W + G\kappa T_R^\circ W = G\kappa(T_g^\circ + T_R^\circ) W \quad (5.29b)$$

$$= G\kappa T_g^\circ W + (F - 1)G\kappa T_0^\circ W \quad (5.29c)$$

where T_g° is the temperature of the source, and T_0° is 290 K.

5.5.3 Line Loss

The difference between amplifier networks and lossy line networks can be viewed in the context of the degradation mechanisms *loss* and *noise*, described earlier. Noisy networks in Sections 5.5.1 and 5.5.2 were discussed with amplifiers in mind. We saw that SNR degradation resulted from injecting additional (amplifier) noise into the link, as shown in Figure 5.15. However, in the case of a lossy line, we shall show that the SNR degradation results from the signal being attenuated while the noise remains fixed (for the case where the line temperature is equal to or less than the source temperature). The degradation effect will nonetheless be measured as an increase in noise figure or effective noise temperature.

Consider the lossy line or network shown in Figure 5.16. Assume the line is matched with its characteristic impedance at the source and at the load. We shall define power loss as

$$L = \frac{\text{input power}}{\text{output power}}$$

Then, the network gain G equals $1/L$ (less than unity for a lossy line). Let all components be at temperature T_g° . The total output noise power flowing from the network into the load is

$$N_{\text{out}} = \kappa T_g^\circ W$$

since the network output appears as a pure resistance at the temperature T_g° . The total power flowing from the load back into the network must also equal N_{out} to ensure thermal equilibrium. Recall that available noise power $\kappa T^\circ W$ is dependent only on temperature, bandwidth, and impedance matching; it is not dependent on the resistance value. N_{out} can be considered to be made up of two components, N_{go} and GN_{Li} , such that

$$N_{\text{out}} = \kappa T_g^\circ W = N_{go} + GN_{Li} \tag{5.30}$$

where

$$N_{go} = G\kappa T_g^\circ W \tag{5.31}$$

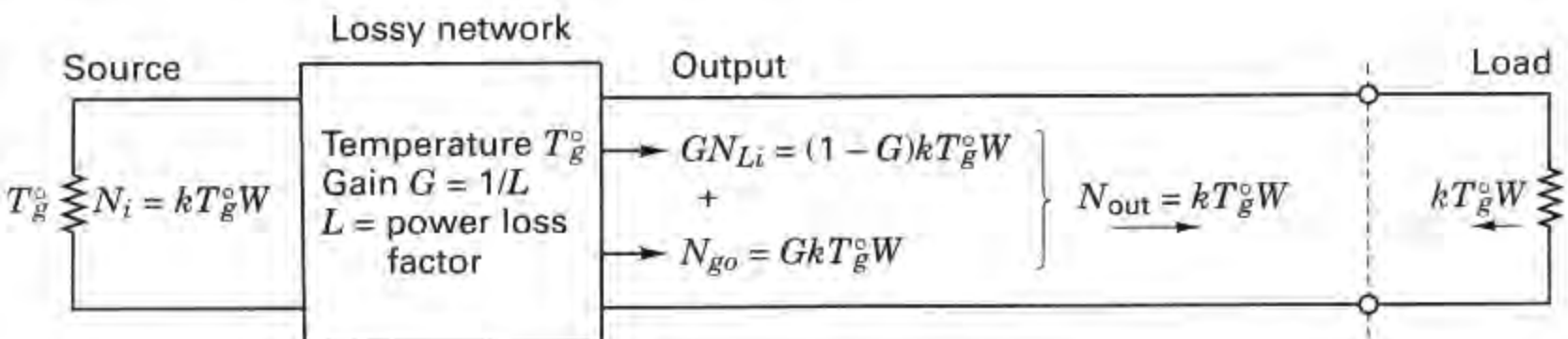

Figure 5.16 Lossy line: impedance matched and temperature matched at both ends.

is the component of output noise power due to the source and GN_{Li} is the component of output noise power due to the lossy network, where N_{Li} is the network noise relative to its input. Combining Equations (5.30) and (5.31), we can write

$$\kappa T_g^\circ W = G\kappa T_g^\circ W + GN_{Li} \quad (5.32)$$

then, solving for N_{Li} yields

$$N_{Li} = \frac{1 - G}{G} \kappa T_g^\circ W = \kappa T_L^\circ W \quad (5.33)$$

Therefore, the effective noise temperature of the line is

$$T_L^\circ = \frac{1 - G}{G} T_g^\circ \quad (5.34)$$

and since $G = 1/L$,

$$T_L^\circ = (L - 1) T_g^\circ \quad (5.35)$$

Choosing $T_g^\circ = 290$ K as the reference temperature, we can write

$$T_L^\circ = (L - 1) 290 \text{ K} \quad (5.36)$$

Using Equations (5.28) and (5.36), the *noise figure for a lossy line* can be expressed as

$$F = 1 + \frac{T_L^\circ}{290} = L \quad (5.37)$$

When the network is a lossy line, such that $F = L$ and $G = 1/L$, then N_{out} in Equation (5.29c) takes the following form:

$$N_{out} = \frac{\kappa T_g^\circ W}{L} + \left(1 - \frac{1}{L}\right) \kappa T_0^\circ W \quad (5.38)$$

Note that some authors use the parameter L to mean the reciprocal of the loss factor defined here. In such cases, noise figure $F = 1/L$.

Example 5.4 Lossy Line

A line at temperature $T_0^\circ = 290$ K is fed from a source whose noise temperature is $T_g^\circ = 1450$ K. The input signal power S_i is 100 picowatts (pW) and the signal bandwidth W is 1 GHz. The line has a loss factor $L = 2$. Calculate the $(\text{SNR})_{in}$, the effective line temperature T_L° , the output signal power S_{out} , and the $(\text{SNR})_{out}$.

Solution

$$\begin{aligned} N_i &= \kappa T_g^\circ W \\ &= 1.38 \times 10^{-23} \text{ W/K-Hz} \times 1450 \text{ K} \times 10^9 \text{ Hz} \\ &= 2 \times 10^{-11} \text{ W} = 20 \text{ pW} \\ (\text{SNR})_{in} &= \frac{100 \text{ pW}}{20 \text{ pW}} = 5 \text{ (7 dB)} \end{aligned}$$

$$T_L^\circ = (L - 1) 290 \text{ K} = 290 \text{ K}$$

$$S_{\text{out}} = \frac{S_i}{L} = \frac{100 \text{ pW}}{2} = 50 \text{ pW}$$

Using Equation (5.39), we obtain

$$\begin{aligned} N_{\text{out}} &= \frac{\kappa T_g^\circ W}{L} + \left(1 - \frac{1}{L}\right) \kappa T_0^\circ W \\ &= \frac{2 \times 10^{-11}}{2} \text{ W} + \frac{1}{2} (4 \times 10^{-12}) \text{ W} = 12 \text{ pW} \end{aligned}$$

and

$$(\text{SNR})_{\text{out}} = \frac{50 \text{ pW}}{12 \text{ pW}} = 4.17 \text{ (6.2 dB)}$$

5.5.4 Composite Noise Figure and Composite Noise Temperature

When two networks are connected in series, as shown in Figure 5.17a, their composite noise figure can be written as

$$F_{\text{comp}} = F_1 + \frac{F_2 - 1}{G_1} \quad (5.39)$$

where G_1 is the gain associated with network 1. When n networks are connected in series the relationship between stages expressed in Equation (5.39) continues, so that the *composite noise figure* for a sequence of n stages is written as

$$F_{\text{comp}} = F_1 + \frac{F_2 - 1}{G_1} + \frac{F_3 - 1}{G_1 G_2} + \dots + \frac{F_n - 1}{G_1 G_2 \dots G_{n-1}} \quad (5.40)$$

Can you guess from Equation (5.40) what the design goals for the front end of the receiver (especially the first stage or the first couple of stages) should be? At the front end of the receiver, the signal is most susceptible to added noise; therefore, the first stage should have as low a noise figure F_1 as possible. Also, because the noise figure of each subsequent stage is reduced by the gains of the prior stages, it behooves us to strive for as high a gain G_1 as possible. Simultaneously achieving the lowest F_1 and the highest G_1 represents conflicting goals; therefore, compromises are always necessary.

Equations (5.40) and (5.28) can be combined to express the composite effective noise temperature of a sequence of n stages:

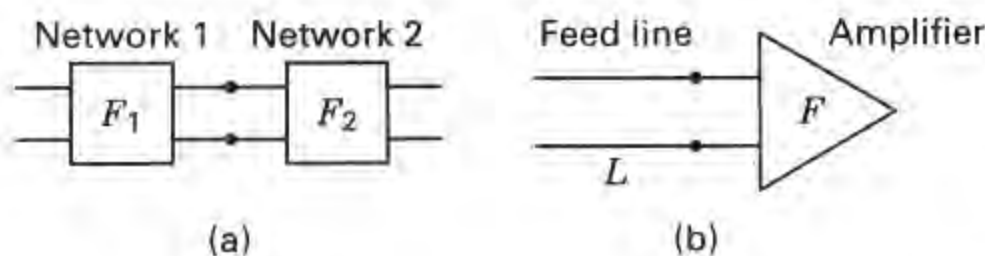

Figure 5.17 Networks connected in series.

$$T_{\text{comp}}^{\circ} = T_1^{\circ} + \frac{T_2^{\circ}}{G_1} + \frac{T_3^{\circ}}{G_1 G_2} + \cdots + \frac{T_n^{\circ}}{G_1 G_2 \cdots G_{n-1}} \quad (5.41)$$

Figure 5.17b illustrates a feed line in series with an amplifier; this is a typical arrangement following a receiving antenna. Using Equation (5.39) to find F_{comp} for such a lossy line and amplifier arrangement, we can write

$$F_{\text{comp}} = L + L(F - 1) = LF \quad (5.42)$$

since the noise figure of the lossy line is L and the gain of the line is $1/L$. By analogy with Equation (5.36), we can write the composite temperature as

$$T_{\text{comp}}^{\circ} = (LF - 1)290 \text{ K} \quad (5.43)$$

We can also write the composite temperature of line and amplifier as follows:

$$\begin{aligned} T_{\text{comp}}^{\circ} &= (LF - 1 + L - L)290 \text{ K} \\ &= [(L - 1) + L(F - 1)]290 \text{ K} \\ &= T_L^{\circ} + LT_R^{\circ} \end{aligned} \quad (5.44)$$

5.5.4.1 Comparison of Noise Figure and Noise Temperature

Since noise figure F and effective noise temperature T° characterize the noise performance of devices, some engineers feel compelled to select one of these measures as the more useful. However, they each have their place. For terrestrial applications, F is almost universally used; the concept of SNR degradation for a 290 K source temperature makes sense, because terrestrial source temperatures are typically close to 290 K. Terrestrial noise figure values typically fall in the convenient range 1 to 10 dB.

For space applications, T° is the more common figure of merit. The range of values for commercial systems is typically between 30 and 150 K, giving adequate resolution for comparing performance between systems. A disadvantage of using noise figures for such low-noise networks is that the values obtained are all close to unity (0.5 to 1.5 dB), which makes it difficult to compare devices. For low-noise applications, F (in decibels) would need to be expressed to two decimal places to provide the same resolution or precision as does T° . For space applications, a reference temperature of 290 K is not as appropriate as it is for terrestrial applications. When using effective temperature, no reference temperature (other than absolute zero K) is needed for judging degradation. The effective input noise temperature is simply compared to the effective source noise temperature. In general, applications involving very low noise devices seem to favor the effective temperature measure over the noise figure.

5.5.5 System Effective Temperature

Figure 5.18 represents a simplified schematic of a receiving system, identifying those areas—the antenna, the line, and the preamplifier—that play a primary role in SNR degradation. We have already discussed the degradation role of the pream-

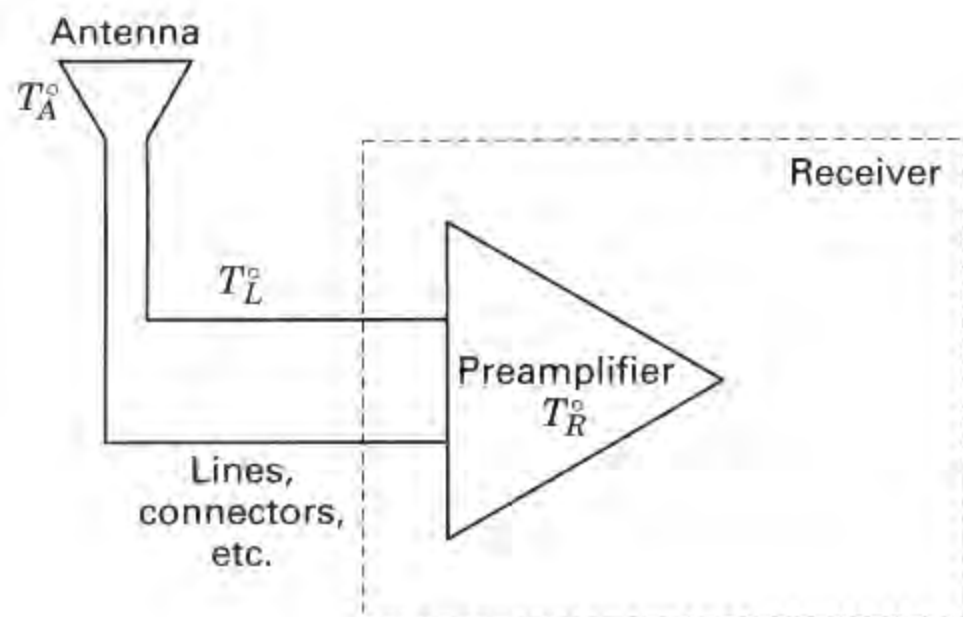

Figure 5.18 Major noise contributors of a receiving system.

plifier—additional noise is injected into the link. And we have discussed line loss—the signal is attenuated, while the noise is held fixed (for the case where the line temperature is less than or equal to the source temperature). The remaining source of degradation stems from both natural and man-made sources of noise and interference that enter the receiving antenna. Natural sources include lightning, celestial radio sources, atmospheric sources, and thermal radiation from the ground and other physical structures. Man-made noise includes radiation from automobile ignition systems and any other electrical machinery, and radio transmissions from other users that fall within the receiver bandwidth. The total noise contributed by these external sources can be characterized by $kT_{\text{ant}}W$, where T_{ant} is known as the *antenna temperature*. An antenna is like a lens. Its noise contributions are dictated by what the antenna is “looking at.” If an antenna is pointed at a cool portion of the sky, very little thermal noise is introduced. The antenna temperature is a measure of the effective temperature integrated over the entire antenna pattern.

We now find *system temperature* T_S^o by adding together all the system noise contributors (in terms of effective temperature). The summation is expressed as

$$T_S^o = T_A^o + T_{\text{comp}}^o \quad (5.45)$$

where T_A^o is the antenna temperature and T_{comp}^o is the composite temperature of the line and the preamplifier. Equation (5.45) illustrates the two primary sources of noise and interference degradation at a receiver. One source, characterized by T_A^o , represents degradation from the “outside world” arriving via the antenna. The second source, characterized by T_{comp}^o , is thermal noise caused by the motion of electrons in all conductors. Since the system temperature T_S^o is a new composite, made up of T_A^o and the composite effective temperature of the line and preamp, one might ask: Why doesn’t Equation (5.45) appear to have the same sequential gain reduction factors as those in Equation (5.41)? We have assumed that the antenna has *no dissipative parts*; its gain, unlike an amplifier or attenuator, can be thought of as a processing gain. Whatever effective temperature is introduced at the antenna comes through, unaltered by the antenna; the antenna represents the source noise, or source temperature, at the input to the line.

Using Equation (5.44), we can modify Equation (5.45) as follows:

$$T_S^{\circ} = T_A^{\circ} + T_L^{\circ} + LT_R^{\circ} \quad (5.46)$$

$$= T_A^{\circ} + (L - 1)290 \text{ K} + L(F - 1)290 \text{ K}$$

$$= T_A^{\circ} + (LF - 1)290 \text{ K} \quad (5.47)$$

If LF is provided in units of decibels, we must first convert LF to a ratio, so that T_S° takes the form

$$T_S^{\circ} = T_A^{\circ} + (10^{LF/10} - 1)290 \text{ K}$$

Equations (5.45) through (5.47) describe the system temperature T_S at the receiving antenna terminals, and Equations (5.10) and (5.11) describe the power received P_r at the receiving antenna. These are the definitions used throughout this chapter and preferred by system designers, antenna designers, and those working at the transmitter side of the link. It is important to note that there is another set of definitions used by receiver designers who prefer to describe the system temperature T_S' and received power P_r' at the input to the receiver. Assuming that the antenna and receiver are connected via nothing more elaborate than a lossy line, then T_S and T_S' (also P_r and P_r') are related by the line-loss factor L . That is, $T_S = LT_S'$, and $P_r = LP_r'$. When computing the received SNR (defined in the next section) by using receiver-reference definitions for power received and system temperature, there is no difference in the result compared to using the original definitions because the factor L appears in both the numerator and denominator of the SNR, and hence cancels out.

Example 5.5 Noise Figure and Noise Temperature

A receiver front end, shown in Figure 5.19a, has a noise figure of 10 dB, a gain of 80 dB, and a bandwidth of 6 MHz. The input signal power, S_i , is 10^{-11} W. Assume that the line is lossless and the antenna temperature is 150 K. Find T_R° , T_S° , N_{out} , $(\text{SNR})_{\text{in}}$, and $(\text{SNR})_{\text{out}}$.

Solution

First convert all decibel values to ratios:

$$T_R^{\circ} = (F - 1)290 \text{ K} = 2610 \text{ K}$$

Using Equation (5.46) with $L = 1$ for a lossless line yields

$$T_S^{\circ} = T_A^{\circ} + T_R^{\circ} = 150 \text{ K} + 2610 \text{ K} = 2760 \text{ K}$$

$$N_{\text{out}} = G\kappa T_A^{\circ} W + G\kappa T_R^{\circ} W = G\kappa T_S^{\circ} W$$

$$= 10^8 \times 1.38 \times 10^{-23} \times 6 \times 10^6 (150 \text{ K} + 2610 \text{ K})$$

$$= \underbrace{1.2 \mu\text{W}}_{\text{source contribution}} + \underbrace{21.6 \mu\text{W}}_{\text{front-end contribution}} = 22.8 \mu\text{W}$$

$$(\text{SNR})_{\text{in}} = \frac{S_i}{\kappa T_A^{\circ} W} = \frac{10^{-11}}{1.24 \times 10^{-14}} = 806.5 \text{ (29.1 dB)}$$

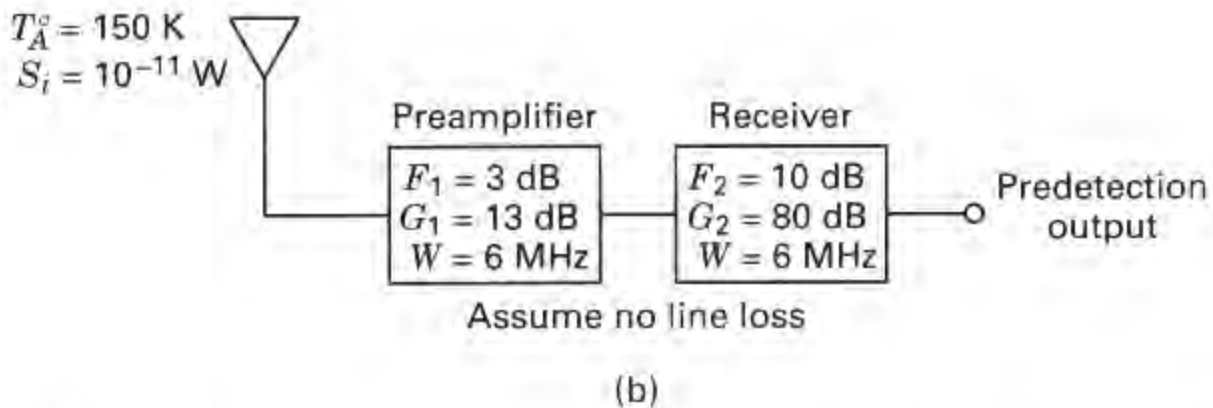
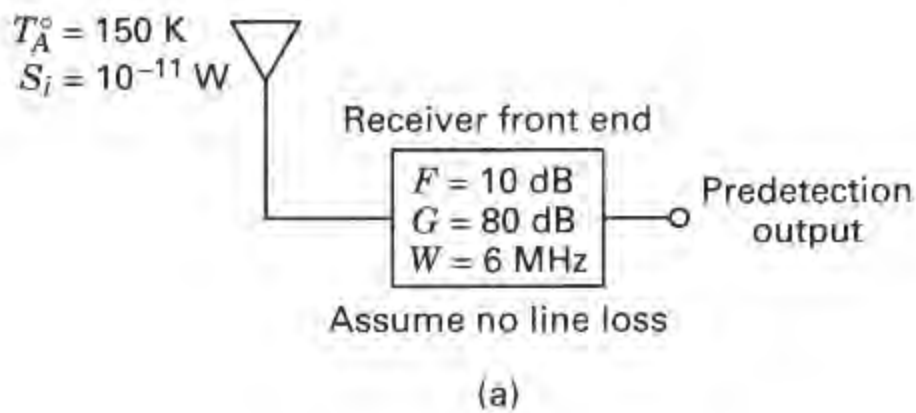

Figure 5.19 Improving a receiver front end with a low-noise preamplifier.

$$(\text{SNR})_{\text{out}} = \frac{S_{\text{out}}}{N_{\text{out}}} = \frac{10^8 \times 10^{-11}}{22.8 \times 10^{-6}} = 43.9 \text{ (16.4 dB)}$$

Notice in this example that the amplifier noise is significantly larger than the source noise and represents the major cause of SNR degradation.

Example 5.6 Improving SNR with a Low-Noise Preamplifier

Use a preamplifier, as shown in Figure 5.19b, with a noise figure of 3 dB, a gain of 13 dB, and a bandwidth of 6 MHz to improve the SNR of the receiver in Example 5.5. Find T_{comp}° for the composite preamplifier and receiver. Find T_S° , F_{comp} , N_{out} , and $(\text{SNR})_{\text{out}}$. Assume zero line loss.

Solution

Again, convert all decibel values to ratios before proceeding:

$$T_{R1}^{\circ} = (F_1 - 1)290 \text{ K} = 290 \text{ K}$$

$$T_{R2}^{\circ} = (F_2 - 1)290 \text{ K} = 2610 \text{ K}$$

$$T_{\text{comp}}^{\circ} = T_{R1}^{\circ} + \frac{T_{R2}^{\circ}}{G_1} = 290 \text{ K} + \frac{2610 \text{ K}}{20} = 420.5 \text{ K}$$

$$T_S^{\circ} = T_A^{\circ} + T_{\text{comp}}^{\circ} = 150 \text{ K} + 420.5 \text{ K} = 570.5 \text{ K}$$

$$F_{\text{comp}} = F_1 + \frac{F_2 - 1}{G_1} = 2 + \frac{9}{20} = 2.5 \text{ (4 dB)}$$

$$\begin{aligned}
 N_{\text{out}} &= G\kappa T_A^{\circ}W + G\kappa T_{\text{comp}}^{\circ}W = G\kappa T_{\Sigma}^{\circ}W \\
 &= 20 \times 10^8 \times 1.38 \times 10^{-23} \times 6 \times 10^6 (150 \text{ K} + 420.5 \text{ K}) \\
 &= \underbrace{24.8 \mu\text{W}}_{\text{source contribution}} + \underbrace{69.6 \mu\text{W}}_{\text{front-end contribution}} = 94.4 \mu\text{W}
 \end{aligned}$$

$$(\text{SNR})_{\text{out}} = \frac{S_{\text{out}}}{N_{\text{out}}} = \frac{10^{-11} \times 20 \times 10^8}{94.4 \times 10^{-6}} = 212.0 \text{ (23.3 dB)}$$

With the added preamplifier the (predetection) output noise has increased (from 22.8 μW in Example 5.5) to 94.4 μW . Even though the noise power has increased, the lower system temperature has resulted in a 6.9-dB improvement in SNR (from 16.4 dB in Example 5.5, to 23.3 dB here). The price we pay for this improvement is the need to provide an F_{comp} improvement of 6 dB (from 10 dB in Example 5.5, to 4 dB in this example).

The unwanted noise is, in part, *injected via the antenna* ($\kappa T_A^{\circ}W$), and in part, *generated internally* in the receiver front end ($\kappa T_{\text{comp}}^{\circ}W$). The amount of system improvement that can be rendered via front-end design depends on what portion of the total noise the front end contributes. We saw in Example 5.5 that the front end contributed the major portion of the noise. Therefore, in Example 5.6, providing a low-noise preamplifier improved the system SNR significantly. In the next example, we show the case where the major portion of the noise is injected via the antenna; we shall see that introducing a low-noise preamplifier in such a case will not help the SNR appreciably.

Example 5.7 Attempting SNR Improvement When the Value of T_A° Is Large

Repeat Examples 5.5 and 5.6 with one change: let $T_A^{\circ} = 8000 \text{ K}$. In other words, the preponderant amount of noise is being injected via the antenna; the antenna might have a very hot body (the sun) fully occupying its field of view. Calculate the SNR improvement that would be provided by the preamplifier used in Example 5.6 and Figure 5.19b, and compare the result with that of Example 5.6.

Solution

Without preamplifier

$$\begin{aligned}
 N_{\text{out}} &= G\kappa W(T_A^{\circ} + T_R^{\circ}) \\
 &= 10^8 \times 1.38 \times 10^{-23} \times 6 \times 10^6 (8000 \text{ K} + 2610 \text{ K}) \\
 &= \underbrace{66.2 \mu\text{W}}_{\text{source contribution}} + \underbrace{21.6 \mu\text{W}}_{\text{front-end contribution}} = 87.8 \mu\text{W}
 \end{aligned}$$

$$(\text{SNR})_{\text{out}} = \frac{S_{\text{out}}}{N_{\text{out}}} = \frac{10^8 \times 10^{-11}}{87.8 \times 10^{-6}} = 11.4 \text{ (10.6 dB)}$$

With preamplifier

$$N_{\text{out}} = 20 \times 10^8 \times 1.38 \times 10^{-23} \times 6 \times 10^6 (8000 \text{ K} + 420.5 \text{ K})$$

$$= \underbrace{1324.8 \mu\text{W}}_{\text{source contribution}} + \underbrace{69.6 \mu\text{W}}_{\text{front-end contribution}} = 1394.4 \mu\text{W}$$

$$(\text{SNR})_{\text{out}} = \frac{20 \times 10^8 \times 10^{-11}}{1.39 \times 10^{-3}} = 14.4 \text{ (11.6 dB)}$$

Therefore, for this case, the SNR improvement is only 1 dB, a far cry from the 6.9 dB accomplished earlier. When the noise is mostly due to devices within the receiver, it is possible to improve the SNR by introducing low-noise devices. However, when the noise is mostly due to external causes, improving the receiver front end will not help much.

Noise figure is a definition, predicated on a reference temperature of 290 K. When the source temperature is other than 290 K, as is the case in Examples 5.5, 5.6, and 5.7, it is necessary to define an *operational* or *effective noise figure* that describes the actual $(\text{SNR})_{\text{in}}$ versus $(\text{SNR})_{\text{out}}$ relationship. Starting with Equations (5.25) and (5.27), the operational noise figure can be found as follows:

$$F_{\text{op}} = \frac{S_i/kT_A W}{GS_i/G(kT_A W + N_{ai})}$$

$$= \frac{kT_A W + N_{ai}}{kT_A W} = 1 + \frac{(F - 1)kT_0 W}{kT_A W} \quad (5.48)$$

$$= 1 + \frac{T_0}{T_A} (F - 1)$$

5.5.6 Sky Noise Temperature

The receiving antenna collects random noise emissions from galactic, solar, and terrestrial sources, constituting the sky background noise. The sky background appears as a combination of galactic effects that decrease with frequency, and atmospheric effects that start becoming significant at 10 GHz and increase with frequency. Figure 5.20 illustrates the sky temperature, as measured from the earth, due to both these effects. Notice that there is a region, between 1 and 10 GHz, where the temperature is lowest; the galaxy noise has become quite small at 1 GHz, and for satellite communications the blackbody radiation noise due to the absorbing atmosphere is not significant below 10 GHz. (For other applications, e.g., passive radiometry, it is still a problem.) This region, known as the *microwave window* or *space window*, is particularly useful for satellite or deep-space communication. The low sky noise is the principal reason that such systems primarily use carrier frequencies in this part of the spectrum. The galaxy and atmospheric noise curves in Figure 5.20 are made up of a family of curves each at a different elevation angle θ . When θ is zero, the receiving antenna points at the horizon and the propagation path encompasses the longest possible atmospheric layer; when θ is 90° , the receiving antenna points to the zenith, and the resulting propagation path contains the shortest possible atmospheric layer. Thus the upper curve of the family repre-

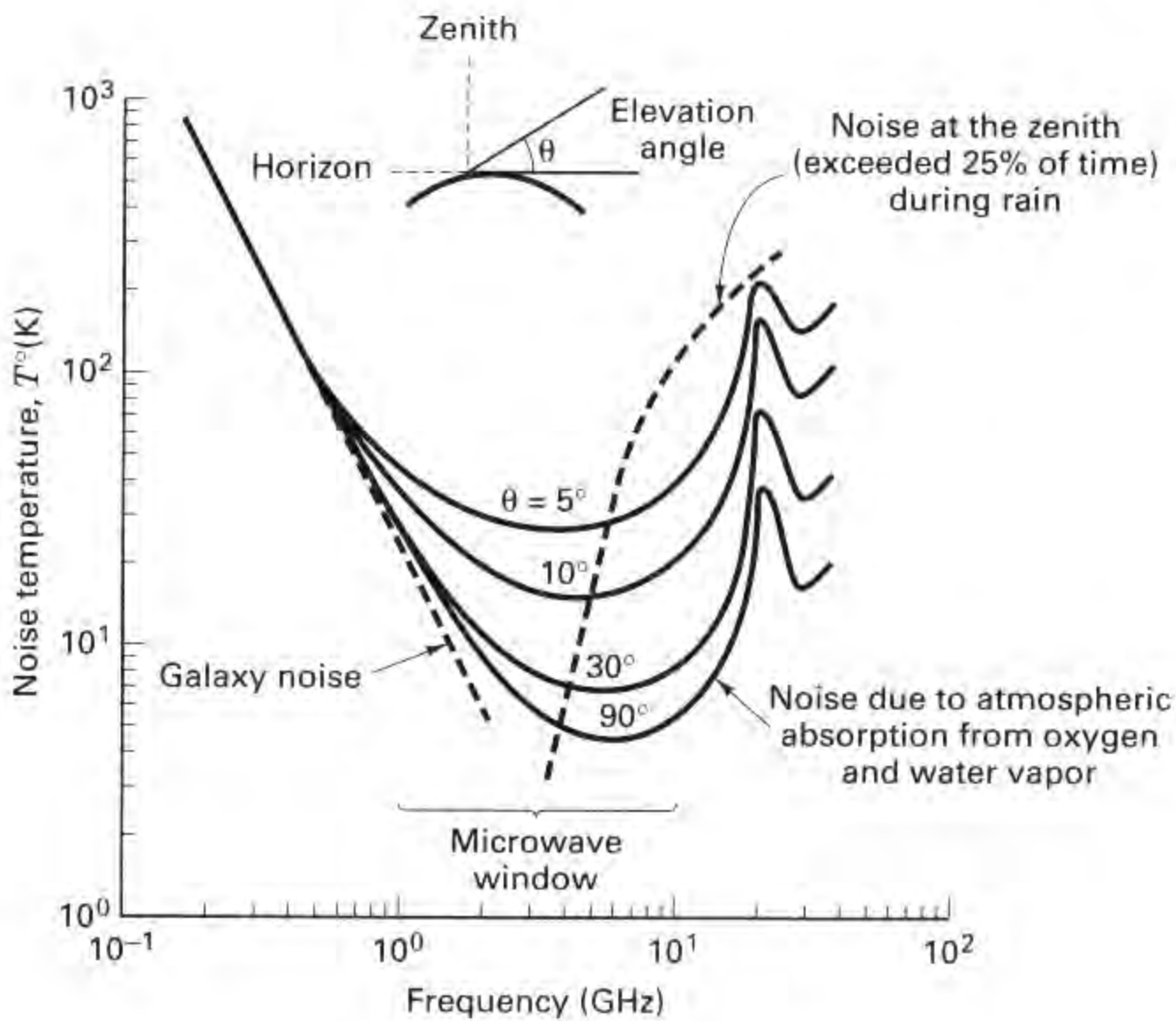
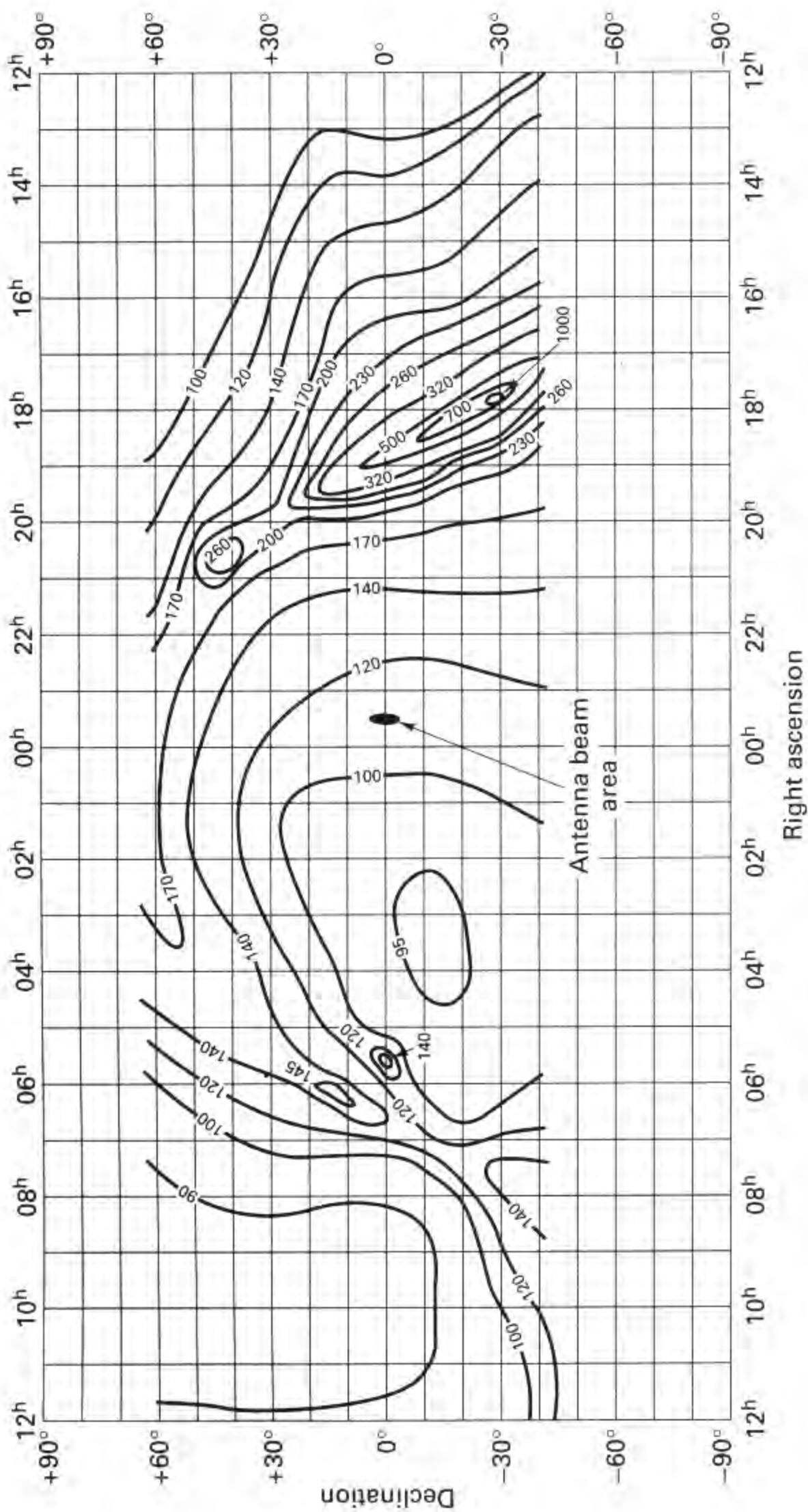

Figure 5.20 Sky noise temperature.

sents the near worst-case (clear-weather) sky noise temperature versus frequency, and the lower curve represents the most benign case. Also shown in Figure 5.20 is a plot of noise temperature versus frequency *due to rain*. Since the intensity of any rainstorm can only be expressed statistically, the noise temperatures shown are values that are exceeded 25% of the time (at the zenith). Which spectral region appears the most benign for space communications when rainfall is taken into account? It is the region at the low end of the space window. For this reason, systems such as the Space Ground Link Subsystem or SGLS (military) and the Unified S-Band Telemetry, Tracking, and Control System (NASA) are located in the 1.8 to 2.4-GHz band.

5.5.6.1 Radio Maps of the Sky

Various researchers have mapped the galactic noise radiation as a function of frequency. Figure 5.21 is such a radio temperature map, after Ko and Kraus [12], indicating the temperature contours of the sky in the region of 250 MHz when viewed from the earth. In general, the sky is composed of localized galactic sources (sun, moon, planets, etc.), each having its own temperature. The map is effectively



Right ascension

Figure 5.21 Radio map of the sky background at 250 MHz. (Reprinted from H. C. Ko and J. D. Kraus, "A Radio Map of the Sky at 1.2 Meters," *Sky Telescope*, vol. 16, Feb. 1957, p. 160, with permission from *Sky and Telescope* astronomy magazine, Cambridge, Mass.)

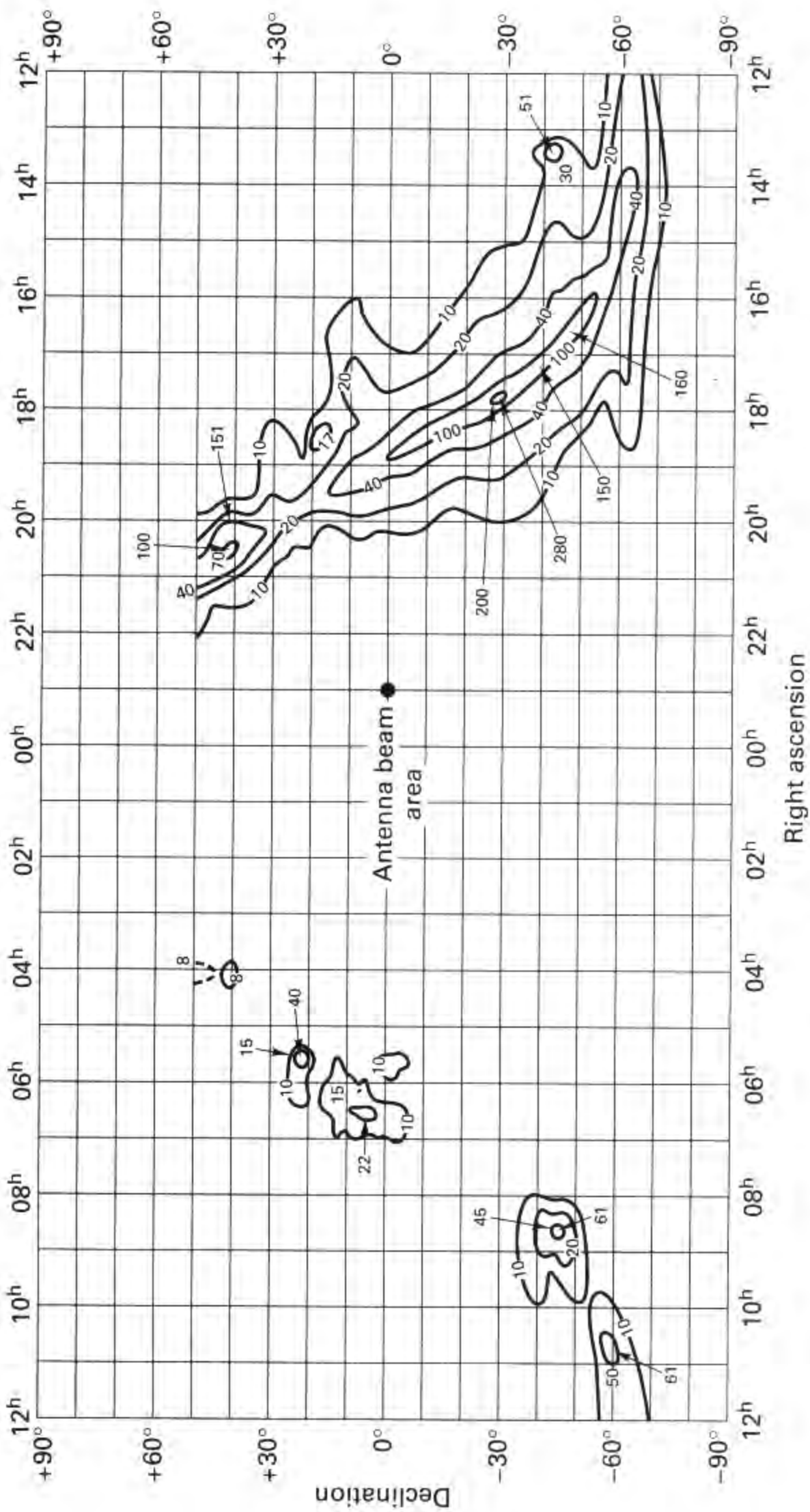

Figure 5.22 Radio map of the sky background at 600 MHz. (Reprinted with permission from J. H. Piddington and G. H. Trent, "A Survey of Cosmic Radio Emission at 600 Mc/s," *Aust. J. Phys.*, vol. 9, Dec. 1956, Fig. 1, pp. 483-486.)

a weighted sum of the individual galactic source temperatures plus a constant sky background. The coordinates of the map, *declination and right ascension*, can be thought of as celestial latitude and longitude with an earth reference (right ascension is calibrated in units of hour-angle, where 24 hours corresponds to a complete rotation of the earth). On Figure 5.21, the temperature contours range from a low of 90 K to a high of 1000K. The measurements were made so as to exclude the sun (night sky). The antenna beam in the center of the map indicates the size of the sky area over which measurements are made (each measurement is an average over that beam area). The narrower the beam, the finer the resolution of the temperature contours; the wider the beam, the coarser the resolution.

Figure 5.22 is another such radio map at 600 MHz, after Piddington and Trent [13]. At this frequency the galaxy noise is reduced compared to Figure 5.21, as predicted in Figure 5.20; the low is 8 K and the high is 280 K. If you examine Figures 5.21 and 5.22 for the region of greatest noise radiation, where on the map do you see the most activity, and what is its significance? It is seen as an elongated region in the right-hand midsection of each map; the longitudinal axis of the elongation designates the location of our *galactic plane*, where such cosmic noise radiation is most intense.

5.6 SAMPLE LINK ANALYSIS

In Section 5.4 we developed the basic link parameter relationships. In this section we use these relationships to calculate a sample link budget, as shown in Table 5.2. The table may appear to house a formidable listing of terms; one can get the false impression that the link budget represents a complex compilation. Just the opposite is true, and we introduce Figure 5.23 to underscore this assertion. In this figure we have reduced the set of line items from Table 5.2 to a few key parameters. The goal of a link analysis is to determine whether or not the required error performance is met, by examining the E_b/N_0 actually received and comparing it with the E_b/N_0 required to meet the system specification. The principal items needed for this determination are the EIRP (how much effective power is transmitted), the G/T° figure of merit (how much capability the receiver has for collecting this power), L_s (the largest single loss, the space loss), and L_o (other contributing losses and degradations). That is *all* there is to it!

5.6.1 Link Budget Details

The link budget example in Table 5.2 consists of three columns of numbers. Only the middle column represents the link budget. The other columns consist of ancillary information, such as antenna beamwidth, or computations to support the main tabulation. Losses are bracketed in the usual bookkeeping way. If a value is not bracketed, it represents a gain. Subtotals are shown enclosed in a box. Starting from the top of the middle column, we algebraically sum all of the gains and losses. The final link margin result is shown in a double box in item 21. The computations

TABLE 5.2 Earth Terminal to Satellite Link Budget Example: Frequency = 8 GHz, Range = 21,915 Nautical Miles.

1. Transmitter power (dBW)	(100.00W)	20.0	P_t
2. Transmitter circuit loss (dB)		(2.0)	L_o
3. Transmitter antenna gain (peak dBi)		51.6	G_t
Dish diameter (ft)	20.00		
Half-power beamwidth (degrees)	0.45		
4. Terminal EIRP (dBW)		69.6	EIRP
5. Path loss (dB)	(10° elev.)	(202.7)	L_s
6. Fade allowance (dB)		(4.0)	L_o
7. Other losses (dB)		(6.0)	L_o
8. Received isotropic power (dBW)		-143.1	
9. Receiver antenna gain (peak dBi)		35.1	G_r
Dish diameter (ft)	3.00		
Half-power beamwidth (degrees)	2.99		
10. Edge-of-coverage loss (dB)		(2.0)	L_o
11. Received signal power (dBW)		-110.0	P_r
Receiver noise figure at antenna port (dB)			11.5
Receiver temperature (dB-K)			35.8 (3806 K)
Receiver antenna temperature (dB-K)			24.8 (300 K)
12. System temperature (dB-K)			36.1 (4106 K)
13. System G/T° (dB/K)	-1.0		G/T°
14. Boltzmann's constant (dBW/K-Hz)			-228.60
15. Noise spectral density (dBW/Hz)		(-192.5)	$N_0 = kT^\circ$
16. Received P_r/N_0 (dB-Hz)		82.5	$(P_r/N_0)_r$
17. Data rate (dB-bit/s)	(2 Mbits/s)	(63.0)	R
18. Received E_b/N_0 (dB)		19.5	$(E_b/N_0)_r$
19. Implementation loss (dB)		(1.5)	L_o
20. Required E_b/N_0 (dB)		(10.0)	$(E_b/N_0)_{reqd}$
21. Margin (dB)		8.0	M

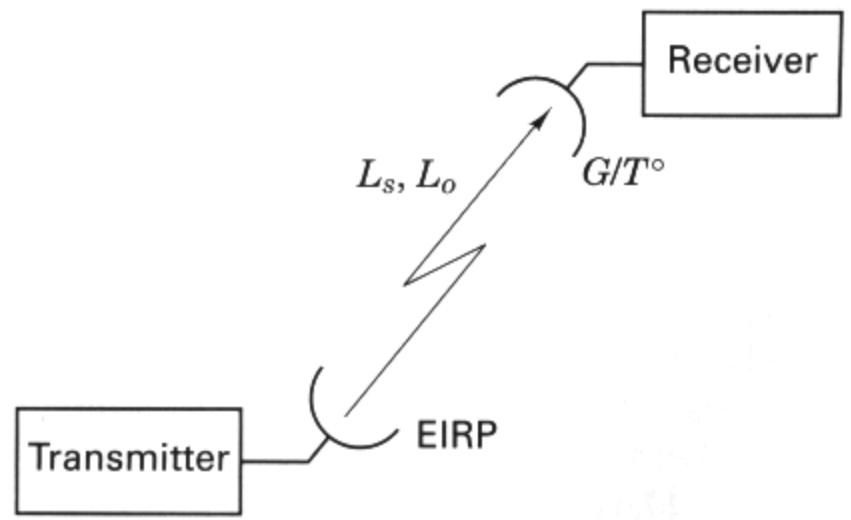

Figure 5.23 Key parameters of a link analysis.

are performed as in Equation (5.24), which is repeated here, with the exception that the terms G_r and T° are grouped together at G_r/T° instead of being listed separately:

$$M(\text{dB}) = \text{EIRP}(\text{dBW}) + \frac{G_r}{T^\circ}(\text{dB/K}) - \left(\frac{E_b}{N_0}\right)_{\text{reqd}}(\text{dB}) - R(\text{dB-bits/s}) \\ - \kappa(\text{dBW/K-Hz}) - L_s(\text{dB}) - L_o(\text{dB})$$

Let us examine the 21 line items listed in Table 5.2.

1. Transmitter power is 100 W (20 dBW).
2. Circuit loss between the transmitter and antenna is 2 dB.
3. Transmitting antenna gain is 51.6 dBi.
4. The net tally of items 1 to 3 yields the EIRP = 69.6 dBW.
5. The path loss has been calculated for the range shown in the table title, corresponding to a 10° elevation angle at the earth terminal.
- 6 and 7. Here are allowances made for weather fades and a variety of other, unspecified losses.
8. Received isotropic power refers to the power that would be received, -143.1 dBW, if the receiving antenna were isotropic.
9. The peak gain of the receiving antenna is 35.1 dBi.
10. Edge-of-coverage loss is due to the off-axis antenna gain (compared to peak gain) and to the increased range for users at the extreme edge of communication coverage (a nominal 2-dB loss is shown here.)
11. The input power to the receiver, tallied from items 8, 9, and 10, is -110 dBW.
12. System temperature is found using Equation (5.46). However, in this example we are assuming a lossless line from the receiver antenna to the front end, so that the line loss factor L is equal to 1, and system temperature is computed in column 3, as $T_S^\circ = T_A + T_R$.
13. We form the receiver figure-of-merit ratio G_r/T° by combining the gain of the receiver antenna G_r (see item 9) with system temperature T_S . This ratio is placed in the left column as a parameter of interest, rather than in the middle column. This is because G_r is accounted for in link budget item 9, and T_S is accounted for in item 15. If G_r/T° were to be placed in the center column, it would represent a double tabulation.
14. Boltzmann's constant is -228.6 dBW/K-Hz.
15. Boltzmann's constant in decibels (item 14), plus system temperature in decibels (item 12), yields noise power spectral density.
16. Finally, we can form the received signal-to-noise spectral density, 82.5 dB-Hz, by subtracting noise spectral density in decibels (item 15), from received signal power in decibels (item 11).
17. The data rate is listed in dB-bit/s.

18. Since $E_b/N_0 = (1/R) (P_r/N_0)$, we need to subtract R in decibels (item 17), from P_r/N_0 in decibels (item 16), yielding $(E_b/N_0)_r = 19.5$ dB.
19. An implementation loss, here taken to be 1.5 dB, accounts for the difference between theoretically predicted detection performance, and the performance of the actual detector.
20. This is our required E_b/N_0 , a result of the modulation and coding chosen, and the probability of error specified.
21. The difference between the received and the required E_b/N_0 in decibels (taking implementation loss into account), yields the final margin.

The gain or loss items shown in a link budget, generally follow the convention of first presenting an *ideal* or *simplistic* result, followed by a gain or loss term that modifies the simplistic yielding an *actual result*. In other words, the link budget typically follows a *modular* approach to partitioning the gains and losses in a way that easily adapts to the needs of any system. Consider the following examples of this format. In Table 5.2, item 1 gives the transmitter power that would be launched from a transmitter with an isotropic transmitting antenna (the simplistic). However, only after applying the modules of circuit loss and transmitter-antenna gain do we see, in item 4, the EIRP (actually) launched. Similarly, item 8 shows the power received by an isotropic antenna (the simplistic). However, only after applying the modules of receiver-antenna gain and edge-of-coverage loss do we see, in item 11, the (actually) received signal power.

5.6.2 Receiver Figure of Merit

An explanation of why receiving antenna gain and system temperature are often grouped together as G/T° , is as follows. In the early days of satellite communications development, the G_r and the T_s° were specified separately. A contractor who agreed to meet these specifications would need to allow himself some safety margin for meeting each specification. Even though the user was generally only interested in the “bottom-line” performance, and not in the explicit value of G_r or T_s° , the contractor would not be able to exploit potential trade-offs. The net result was an overspecified (more costly) system than was necessary. Recognition of such overspecification resulted in specifying the antenna and receiver front end as a single figure-of-merit parameter G/T° (sometimes called the *receiver sensitivity*), such that cost-effective trade-offs between the antenna design and the receiver design might be employed.

5.6.3 Received Isotropic Power

Another recognized area of overspecification in receiver design is in the separate specification of the required P_r/N_0 (or E_b/N_0) and receiver G/T° . If P_r/N_0 and G/T° are specified separately, the system contractor is forced to meet each value. The contractor will plan for a margin in both places. As in the G/T° case of the preceding section, there are advantages in specifying P_r/N_0 and G/T° as one parameter;

this new parameter, called the *received isotropic power* (RIP), can be written as follows:

$$\text{RIP (dBW)} = \frac{P_r}{N_0} (\text{dB-Hz}) - \frac{G}{T^{\circ}} (\text{dB/K}) + \kappa (\text{dBW/K-Hz}) \quad (5.49)$$

Or, in terms of ratios, it also can be written as

$$\text{RIP} = \frac{P_r}{\kappa T^{\circ}} \left(\frac{\kappa T^{\circ}}{G_r} \right) = \frac{P_r}{G_r} \quad (5.50)$$

It is important to note that P_r/N_0 refers to the predetection signal-to-noise spectral density ratio (SNR) *required* for a particular error probability when using a particular modulation scheme (it usually includes an allowance for *detector implementation losses*). Let us designate the theoretically required SNR to yield a particular P_B as $(P_r/N_0)_{\text{th-rq}}$. We can therefore write

$$\frac{P_r}{N_0} = L'_o \left(\frac{P_r}{N_0} \right)_{\text{th-rq}} \quad (5.51)$$

where L'_o is called the implementation loss and accounts for the hardware and operational losses in the detection process. Combining Equations (5.50) and (5.51), we can write

$$\text{RIP} = L'_o \left(\frac{P_r}{\kappa T^{\circ}} \right)_{\text{th-rq}} \frac{\kappa T^{\circ}}{G_r} \quad (5.52)$$

Specifying the RIP required to meet the system error performance allows the contractor to commit to meeting a single parameter value. The contractor is allowed to trade off P_r/N_0 versus G/T° and L'_o performance. As G/T° is improved, the detector performance can be degraded, and vice versa.

5.7 SATELLITE REPEATERS

Satellite repeaters retransmit the messages they receive (with a translation in carrier frequency). A *regenerative* (digital) repeater regenerates, that is, demodulates and reconstitutes the digital information embedded in the received waveforms before retransmission; however, a *nonregenerative* repeater only amplifies and retransmits. A nonregenerative repeater, therefore, can be used with many different modulation formats (simultaneously or sequentially without any switching), but a regenerative repeater is usually designed to operate with only one, or a very few, modulation formats. A link analysis for a regenerative satellite repeater treats the uplink and downlink as two separate point-to-point analyses. To calculate the overall bit error performance of a regenerative repeater link, it is necessary to determine separately the bit error probability on the uplink and downlink. Let P_u and P_d be the probability of a bit being in error on the uplink and downlink, respectively. A bit will be correct in the end-to-end link if either the bit is correct on both the

up- and downlink, or if it is in error on both the up- and downlink. Therefore, the overall probability that a bit is correct is

$$P_c = (1 - P_u)(1 - P_d) + P_u P_d \quad (5.53)$$

and the overall probability that a bit is in error is

$$P_B = 1 - P_c = P_u + P_d - 2P_u P_d \quad (5.54)$$

For low values of P_u and P_d , the overall bit error performance is approximated simply by summing the individual uplink and downlink bit error probabilities:

$$P_B \approx P_u + P_d \quad (5.55)$$

5.7.1 Nonregenerative Repeaters

Link analysis for a nonregenerative repeater treats the entire “round trip” (uplink transmission to the satellite and downlink retransmission to an earth terminal) as a single analysis. Features that are unique to nonregenerative repeaters, are the dependence of the overall SNR on the uplink SNR and the sharing of the repeater downlink power in proportion to the uplink power from each of the various uplink signals and noise. Henceforth, reference to a repeater or transponder will mean a *nonregenerative repeater*, and for simplicity, we will assume that the transponder is operating in its linear range.

A satellite transponder is limited in transmission capability by its downlink power, the earth terminal’s uplink power, satellite and earth terminal noise, and channel bandwidth. One of these usually is a dominant performance constraint; most often the downlink power or the channel bandwidth proves to be the major system limitation. Figure 5.24 illustrates the important link parameters of a linear satellite repeater channel. The repeater transmits all uplink signals (or noise, in the absence of signal) without any processing beyond amplification and frequency translation. Let us assume that there are multiple simultaneous uplinks within the receiver’s bandwidth W and that they are separated from one another through the use of a technique called *frequency-division multiple access (FDMA)*. FDMA is a communications resource-sharing technique whereby different users occupy disjoint portions of the transponder bandwidth; FDMA is treated in Chapter 11. The satellite effective downlink power EIRP_s is constant and since we are assuming a linear transponder, EIRP_s is shared among the multiple uplink signals (and noise) in proportion to their respective input power levels.

The transmission starts from a ground station (bandwidth $\leq W$), say terminal i , with a terminal $\text{EIRP}_{ti} = P_{ti}G_{ti}$. Simultaneously, other signals are being transmitted to the satellite (from other terminals). The EIRP from the k th terminal will henceforth be referred to simply as P_k . At the satellite, a total signal power $P_T = \sum A_k P_k$ is received, where A_k reflects the uplink propagation loss and the satellite receive antenna gain for each terminal. $N_s W$ is the satellite uplink noise power, where N_s is the composite noise power spectral density due to noise radiated into the satellite antenna *and* generated in the satellite receiver. The total satellite downlink $\text{EIRP}_s = P_s G_{ts}$, where P_s is the satellite transponder output power and G_{ts}

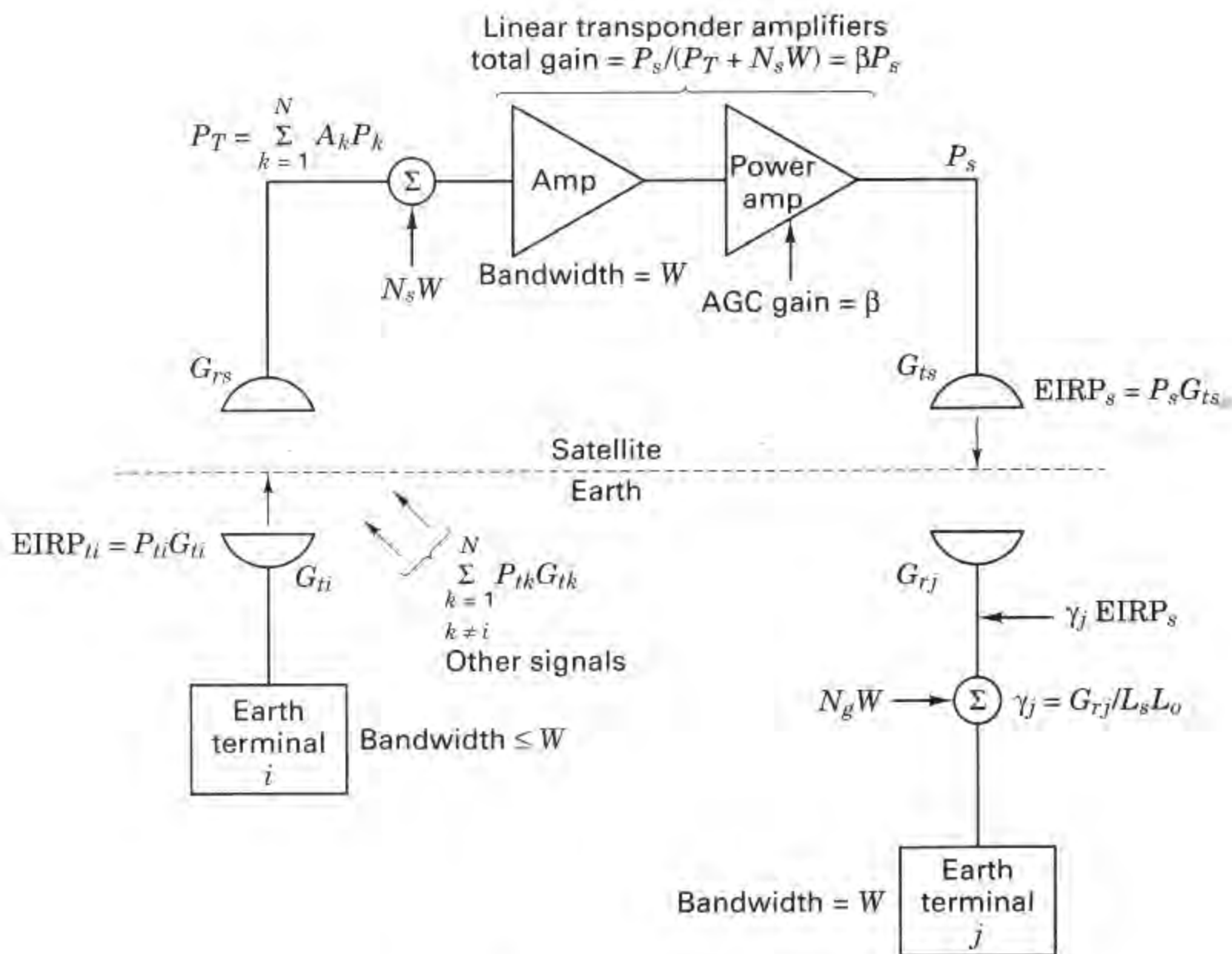

Figure 5.24 Nonregenerative satellite repeater.

is the satellite transmitting antenna gain, can be expressed by the following identity [14]:

$$EIRP_s = EIRP_s \beta [A_i P_i + (P_T - A_i P_i) + N_s W] \quad (5.56)$$

Both the left and right sides of Equation (5.56) express the total satellite EIRP. On the right side, the term $\beta [A_i P_i + (P_T - A_i P_i) + N_s W]$ constitutes the fractional apportionment of $EIRP_s$ for the various users and uplink noise, such that the composite expression equals unity. The usefulness of this identity should become clear shortly. The total power gain of the transponder can be expressed as βP_s . Since P_s is fixed and the input signals can vary, $\beta = 1/(P_T + N_s W)$ represents an automatic gain control (AGC) term. The total received uplink signal power, P_T , has purposely been written as $A_i P_i + (P_T - A_i P_i)$ to separate signal i power from the remainder of the simultaneous signals in the transponder. The total power received at the j th earth terminal, with bandwidth W , can be written as

$$P_{rj} = EIRP_s \gamma_j \beta [A_i P_i + (P_T - A_i P_i) + N_s W] + N_g W \quad (5.57)$$

where $\gamma_j = G_{rj}/L_s L_o$ accounts for downlink losses and receiving antenna gain for the j th earth terminal. $\text{EIRP}_s \gamma_j$ represents the portion of EIRP_s that is received by the j th earth terminal, and N_g is the downlink noise power spectral density generated and introduced into that terminal receiver. Equation (5.57) describes the essence of downlink power apportionment among the various users and noise in a repeater. Let us rewrite Equation (5.57) by replacing β with its equivalent $1/(P_T + N_s W)$, as follows:

$$P_{rj} = \text{EIRP}_s \gamma_j \left(\frac{A_i P_i}{P_T + N_s W} + \frac{P_T - A_i P_i}{P_T + N_s W} + \frac{N_s W}{P_T + N_s W} \right) + N_g W \quad (5.58)$$

To facilitate our discussion, let us amplify Equation (5.58) with words, yielding

$$P_{rj} = \text{EIRP}_s \gamma_j \left(\frac{S_i \text{ U/L power}}{\text{total } (S + N) \text{ U/L power}} + \frac{\text{balance } S \text{ U/L power}}{\text{total } (S + N) \text{ U/L power}} + \frac{\text{U/L noise power}}{\text{total } (S + N) \text{ U/L power}} \right) + N_g W$$

where S stands for signal power, N for noise power, and U/L for uplink.

From Equation (5.58), can you recognize an important relationship that must exist among multiple users sharing a nonregenerative transponder? The users must *cooperate with one another*, by not exceeding agreed-upon uplink transmission power levels. Equation (5.58) states that the portion of the downlink EIRP dedicated to any one user (or to uplink noise) is determined by the ratio of that user's uplink power to the total uplink signal plus noise power. Hence if one of the sharing users should choose to "cheat" by increasing his or her uplink power, the effect would be an enhancement of this user's downlink signal level, at the expense of the other users' downlink signal levels. Notice from Equation (5.58) that the uplink noise shares the downlink resource along with the other users. This coupling of uplink noise onto the downlink is a feature unique to nonregenerative repeaters.

From Equation (5.58) we can express the P_r/N for signal i received at the j th terminal as

$$\left(\frac{P_r}{N} \right)_{ij} \approx \frac{\text{EIRP}_s \gamma_j [A_i P_i / (P_T + N_s W)]}{\text{EIRP}_s \gamma_j [N_s W / (P_T + N_s W)] + N_g W} \quad (5.59)$$

and we can write the overall P_r/N_0 for signal i received at the j th terminal as [14]

$$\left(\frac{P_r}{N_0} \right)_{ij} = \frac{\text{EIRP}_s \gamma_j \beta A_i P_i}{\text{EIRP}_s \gamma_j \beta N_s + N_g} \quad (5.60)$$

Equations (5.58) to (5.60) illustrate that the uplink repeater noise degrades the overall SNR in two ways—it "steals" downlink EIRP, and it contributes to the total system noise. When the satellite uplink noise dominates—that is, when $P_T \ll N_s W$, the link is said to be *uplink limited*, and most of the downlink EIRP_s is wastefully allocated to uplink noise power. When this is the case and when $\text{EIRP}_s \gamma_j \gg N_g W$, we can rewrite Equation (5.60) as

$$\left(\frac{P_r}{N_0}\right)_{ij} \approx \frac{\text{EIRP}_s \gamma_j A_i P_i / N_s W}{(\text{EIRP}_s \gamma_j / W) + N_g} \approx \frac{A_i P_i}{N_s} \quad (5.61)$$

Equation (5.61) illustrates that in the case of an uplink limited channel, the overall P_r/N_0 ratio essentially follows the uplink SNR. The more common situation is the *downlink limited* channel, in which case $P_T \gg N_s W$, and the satellite EIRP is limited. In this case, Equation (5.60) can be rewritten as

$$\left(\frac{P_r}{N_0}\right)_{ij} \approx \frac{\text{EIRP}_s \gamma_j A_i P_i / P_T}{N_g} \quad (5.62)$$

The power of the transponder is then shared primarily among the various uplink transmitted signals; very little uplink noise is transmitted on the downlink. The performance of the repeater, in this case, is constrained only by its downlink parameters.

Table 5.3 illustrates a link analysis example (full round trip) for a nonregenerative repeater. The uplink portion by itself does not constitute a link budget since the transmission is not demodulated at the satellite. Without demodulation, *there are no bits* and therefore there is no way to measure the bit-error performance. After the full round trip, the signal is demodulated at the earth terminal; only then does the link analysis yield the margin. The example in Table 5.3 represents a case where the satellite transponder is servicing 10 simultaneous users. In the block marked "A" is shown the ratio $P_r/(P_T + N_s W)$, which dictates the apportionment of the downlink EIRP for the signal of interest. In this example, with all users transmitting the same power level, each of the signals is allocated 9.8% of the downlink EIRP. In the block marked "B" we see the apportionment of the downlink EIRP. The total is 1514.7 W; the user of interest gets 148.5 W; the other nine users get a total of 1336.1 W; and the uplink noise is apportioned 30.1 W.

An estimate of the performance described in Equation (5.60) can be obtained by using the uplink and downlink values of E_b/N_0 (or P_r/N_0), combined as follows, in the *absence of intermodulation noise* [15].

$$\left(\frac{E_b}{N_0}\right)_{ov}^{-1} = \left(\frac{E_b}{N_0}\right)_u^{-1} + \left(\frac{E_b}{N_0}\right)_d^{-1} \quad (5.63)$$

where the subscripts *ov*, *u*, and *d*, indicate overall, uplink, and downlink values of E_b/N_0 , respectively.

Most commercial satellite transponder designs are nonregenerative. However, it seems clear that future commercial systems will require on-board processing, switching, or selective message addressing, and will use regenerative repeaters to transform the received waveforms to message bits. Besides the potential for sophisticated data processing, one of the principal advantages of regenerative compared to nonregenerative repeaters is that the uplink is decoupled from the downlink so that the uplink noise is not retransmitted on the downlink. There are significant performance improvements possible with regenerative satellite repeaters in terms of the E_b/N_0 values needed on the uplinks and downlinks, relative to the values needed for the conventional nonregenerative designs in use today. Improvements of as much as 5 dB on the uplink and 6.8 dB on the downlink (using coherent QPSK modulation, with $P_B = 10^{-4}$) have been demonstrated [16].

TABLE 5.3 Link Budget Example For a Nonregenerative Satellite Repeater with 10 Users: Uplink Frequency = 375 MHz, Downlink Frequency = 275 MHz, Range = 22,000 Nautical Miles

	Uplink		Downlink	
Transmitter power (dBW)	27.0	(500.0 W)	13.0	(20.0 W)
Transmitter circuit losses (dB)	1.0		1.0	
Transmitter antenna gain (peak-dBi)	19.0		19.8	
Dish diameter (ft)	10.00		15.00	
Half-power beamwidth (degrees)	19.16		17.42	
EIRP (dBW)	45.0		31.8	(1514.7 W)
Path loss (dB)	176.1		173.4	
Transmitted signal power (dBW)			21.7	(148.5 W)
Transmitted other signal power (dBW)			31.3	(1336.1 W)
Transmitted U/L noise power (dBW)			14.8	(30.1 W)
Other losses (dB)	2.0		2.0	
Received isotropic signal power (dBW)	-133.1		-153.7	
Received isotropic U/L noise power (dBW)			-160.6	
Receiver antenna gain (peak dBi)	22.5		16.3	
Dish diameter (ft)	15.00		10.00	
Half-power beamwidth (degrees)	12.77		26.13	
Received signal power (dBW)	-110.6		-137.4	
Received U/L noise power (dBW)			-144.3	
Receiver antenna temperature (dB-K)	24.6	(290 K)	20.0	(100 K)
Receiver noise figure at antenna port (dB)	10.8		2.0	
Receiver temperature (dB-K)	35.1	(3197 K)	22.3	(170 K)
System temperature (dB-K)	35.4	(3487 K)	24.3	(270 K)
System G/T° (dB/K)	-12.9		-8.0	
Boltzmann's constant (dBW/K-Hz)	-228.6		-228.6	
Noise spectral density (dBW/Hz)	-193.2		-204.3	
System bandwidth (dB-Hz)	75.6	(36.0 MHz)	75.6	(36.0 MHz)
Noise power (dBW)	-117.6		-128.7	
U/L noise + D/L noise power (dBW)			-128.6	
Simultaneous accesses	10			
Received other signal power (dBW)	-101.1			
Other signals + noise (dBW)	-101.0			
$P_r/(P_T + N_s W)$ (dB)	-10.1	(0.098)		
P_r/N (dB)	7.0		-8.7	
Overall P_r/N (dB)			-8.8	
P_r/N_0 (dB-Hz)	82.6		66.9	
Overall P_r/N_0 (dB-Hz)			66.8	
Data rate (dB-bit/s)			50.0	(100,000 bits/s)
Available E_b/N_0 (dB)			16.8	
Required E_b/N_0 (dB)			10.0	
Margin (dB)			6.8	

B

A

5.7.2 Nonlinear Repeater Amplifiers

Power is severely limited in most satellite communication systems, and the inefficiencies associated with linear power amplification stages are expensive to bear. For this reason, many satellite repeaters employ nonlinear power amplifiers. Efficient power amplification is obtained at the cost of signal distortion due to nonlinear operation. The major undesirable effects of the repeater nonlinearities are:

1. Intermodulation (IM) noise due to the interaction of different carriers. The harm is twofold; useful power can be lost from the channel as IM energy (typically 1 to 2 dB), and spurious IM products can be introduced into the channel as interference. The latter problem can be quite serious.
2. AM-to-AM conversion is a phenomenon common to nonlinear devices such as traveling wave tubes (TWT). At the device input, any signal-envelope fluctuations (amplitude modulation) undergo a nonlinear transformation and thus result in amplitude distortion at the device output. Hence, a TWT operating in its nonlinear region would not be the optimum power-amplifier choice for an amplitude-based modulation scheme (such as QAM).
3. AM-to-PM conversion is another phenomenon common to nonlinear devices. Fluctuations in the signal envelope produce phase variations that can affect the error performance for any phase-based modulation scheme (such as PSK or DPSK).
4. In hard limiters, weak signals can be suppressed, relative to stronger signals, by as much as 6 dB [2]. In saturated TWTs, the suppression of weak signals is due not only to limiting, but also to the fact that the signal coupling mechanism of the tube is optimized in favor of the stronger signals. The effect can cause weak signals to be suppressed by as much as 18 dB [17].

Conventional nonregenerative repeaters are generally operated *backed-off* from their highly nonlinear saturated region; this is done to avoid appreciable IM noise and thus to allow efficient utilization of the system's entire bandwidth. However, backing off to the linear region is a compromise; some level of IM noise must be accepted to achieve a useful level of output power.

5.8 SYSTEM TRADE-OFFS

The link budget example in Table 5.3 is a resource allocation document. With such a link tabulation, one can examine potential system trade-offs and attempt to optimize system performance. The link budget is a natural starting point for considering all sorts of potential trade-offs: margin versus noise figure, antenna size versus transmitter power, and so on. Table 5.4 represents an example of a computer exercise for examining a possible trade-off between the earth station transmitting power and the system noise margin at the receiving terminal. The first row in the table is taken from the Table 5.3 link budget. Suppose a system engineer is concerned that a 500-W transmitter is not practical because of some physical con-

TABLE 5.4 Potential Trade-Off: P_t versus Margin

P_t (W)	$(P_r/N_0)_u$ (dB-Hz)	$(P_r/N_0)_d$ (dB-Hz)	$(P_r/N_0)_{ov}$ (dB-Hz)	Margin (dB)
500.0	82.6	66.9	66.8	6.8
250.0	79.6	66.8	66.6	6.6
125.0	76.6	66.6	66.2	6.2
62.5	73.6	66.3	65.5	5.5
31.3	70.5	65.7	64.5	4.5
15.6	67.5	64.8	62.9	2.9
7.8	64.5	63.3	60.8	0.8
3.9	61.5	61.4	58.4	-1.6
2.0	58.4	59.0	55.7	-4.3
1.0	55.4	56.4	52.9	-7.2
0.5	52.4	53.6	49.9	-10.1

straints within the transmitting earth terminal or that such a transmitter makes the system “uplink rich” (a poor design point). The engineer might then consider a trade-off of transmitter power versus thermal noise margin. The listing of candidate trade-offs is a trivial task for a computer. Table 5.4 was generated by repeating the link budget computation multiple times, and at each iteration, reducing P_t by one-half.

The result is a selection of transmitters (in steps of 3 dB) and uplink, downlink, and overall SNRs, and margin, associated with each transmitter value. The system engineer need only peruse the list to find a likely candidate. For example, if the engineer were satisfied with a margin of 3 to 4 dB, it appears he could reduce the transmitter from 500 W to 20 or 30 W. Or, he might be willing to provide a transmitter with, say, $P_t = 100$ W, since he may want to consider additional trade-offs (perhaps because of having misgivings about one of the other subsystems, say the antenna size). The engineer would then start a new tabulation with $P_t = 100$ W, and again perform a succession of link budget computations, to produce a similar enumeration of other possible trade-offs.

Notice from Table 5.4 that one can recognize the uplink-limited and downlink-limited regions, discussed earlier. In the first few rows, where the uplink SNR is high, a 3-dB degradation in uplink SNR results in only a few tenths of a decibel degradation to the overall SNR. Here the system is *downlink limited*; that is, the system is constrained primarily by its downlink parameters and is hardly affected by the uplink parameters. In the bottom few rows of the table, we see that a 3-dB degradation to the uplink affects the overall SNR by almost 3 dB. Here the system is *uplink limited*; that is, the system is constrained primarily by the uplink parameters.

5.9 CONCLUSION

Of the many analyses that support a developing communication system, the link budget stands out in its ability to provide overall system insight. By examining the link budget, one can learn many things about the overall system design and performance. For example, from the link margin, one learns whether the system will meet

its requirements comfortably, marginally, or not at all. It will be evident if there are any hardware constraints, and whether such constraints can be compensated for in other parts of the link. The link budget is often used for considering system trade-offs and configuration changes, and in understanding subsystem nuances and interdependencies. Together with other modeling techniques, the link budget can help predict weight, size, and cost. We have considered how to formulate this budget and how it might be used for system trade-offs. The link budget is one of the system manager's most useful documents; it represents a "bottom-line" tally in the search for optimum error performance of the system.

REFERENCES

1. Panter, P. F., *Communication Systems Design: Line-of-Sight and Tropo-Scatter Systems*, R. E. Krieger Publishing Co, Inc., Melbourne, Fla., 1982.
2. Jones, J. J., "Hard Limiting of Two Signals in Random Noise," *IEEE Trans. Inf. Theory*, vol. IT9, January 1963.
3. Silver, S., *Microwave Antenna Theory and Design*, MIT Radiation Laboratory Series, Vol. 12, McGraw-Hill Book Company, New York, 1949.
4. Kraus, J. D., *Antennas*, McGraw-Hill Book Company, New York, 1950.
5. Johnson, J. B., "Thermal Agitation of Electricity in Conductors," *Phys. Rev.*, vol. 32, July 1928, pp. 97-109.
6. Nyquist, H., "Thermal Agitation of Electric Charge in Conductors," *Phys. Rev.*, vol. 32, July 1928, pp. 110-113.
7. Desoer, C. A., and Kuh, E. S., *Basic Circuit Theory*, McGraw-Hill Book Company, New York, 1969.
8. Schwab, L. M., "World-Wide Link Availability for Geostationary and Critically Inclined Orbits Including Rain Attenuation Effects," *Lincoln Laboratory, Rep. DCA-9*, Jan. 27, 1981.
9. Friis, H. T., "Noise Figure of Radio Receivers," *Proc. IRE*, July 1944, pp. 419-422.
10. IRE Subcommittee 7.9 on Noise, "Description of the Noise Performance of Amplifiers and Receiving Systems," *Proc. IEEE*, Mar. 1963, pp. 436-442.
11. Blackwell, L. A., and Kotzebue, K. L., *Semiconductor Diode Parametric Amplifiers*, Prentice-Hall, Inc., Englewood Cliffs, N.J., 1961.
12. Ko, H. C., and Kraus, J. D., "A Radio Map of the Sky at 1.2 Meters," *Sky Telesc.*, vol. 16, Feb. 1957, pp. 160-161.
13. Piddington, J. H., and Trent, G. H., "A Survey of Cosmic Radio Emission at 600 Mc/s," *Aust. J. Phys.*, vol. 9, Dec. 1956, pp. 481-493.
14. Spilker, J. J., *Digital Communications by Satellite*, Prentice-Hall, Inc., Englewood Cliffs, N.J., 1977.
15. Pritchard, W. L., and Sciulli, J. A., *Satellite Communication Systems Engineering*, Prentice-Hall, Inc., Englewood Cliffs, N.J., 1986.
16. Campanella, S. J., Assal, F., and Berman, A., "Onboard Regenerative Repeaters," *Int. Conf. Commun.*, Chicago, vol. 1, 1977, pp. 6.2-121-66.2-125.
17. Wolkstein, H. J., "Suppression and Limiting of Undesired Signals in Travelling-Wave-Tube Amplifiers," Publication ST-1583, *RCA Rev.*, vol. 22, no. 2, June 1961, pp. 280-291.

PROBLEMS

- 5.1. (a)** What is the value in decibels of the free-space loss for a carrier frequency of 100 MHz and a range of 3 miles?
- (b)** The transmitter output power is 10 W. Assume that both the transmitting and receiving antennas are isotropic and that there are no other losses. Calculate the received power in dBW.
- (c)** If in part (b) the EIRP is equal to 20 W, calculate the received power in dBW.
- (d)** If the diameter of a dish antenna is doubled, calculate the antenna gain increase in decibels.
- (e)** For the system of part (a), what must the diameter of a dish antenna be in order for the antenna gain to be 10 dB? Assume an antenna efficiency of 0.55.
- 5.2.** A transmitter has an output of 2 W at a carrier frequency of 2 GHz. Assume that the transmitting and receiving antennas are parabolic dishes each 3 ft in diameter. Assume that the efficiency of each antenna is 0.55.
- (a)** Evaluate the gain of each antenna.
- (b)** Calculate the EIRP of the transmitted signal in units of dBW.
- (c)** If the receiving antenna is located 25 miles from the transmitting antenna over a free-space path, find the available signal power out of the receiving antenna in units of dBW.
- 5.3.** From Table 5.1 we see that the proposal from Satellite Television Corporation called for a direct broadcast satellite (DBS) EIRP of 57 dBW and a downlink transmission frequency of 12.5 GHz. Assume that the only loss is the downlink space loss shown. Suppose that the downlink information consists of a digital signal with a data rate of 5×10^7 bits/s. Assume that the required E_b/N_0 is 10 dB, the system temperature at your home receiver is 600 K, and that your rooftop dish has an efficiency of 0.55. What is the minimum dish diameter that you can use in order to close the link? Do you think the neighbors will object?
- 5.4.** An amplifier has an input and output resistance of 50Ω , a 60-dB gain, and a bandwidth of 10 kHz. When a $50\text{-}\Omega$ resistor at 290 K is connected to the input, the output rms noise voltage is $100 \mu\text{V}$. Determine the effective noise temperature of the amplifier.
- 5.5.** An amplifier has a noise figure of 4 dB, a bandwidth of 500 kHz, and an input resistance of 50Ω . Calculate the input signal voltage needed to yield an output SNR = 1 when the amplifier is connected to a signal source of 50Ω at 290 K.
- 5.6.** Consider a communication system with the following specifications: transmission frequency = 3 GHz, modulation format is BPSK, bit-error probability = 10^{-3} , data rate = 100 bits/s, link margin = 3 dB, EIRP = 100 W, receiver antenna gain = 10 dB, distance between transmitter and receiver = 40,000 km. Assume that the line loss between the receiving antenna and the receiver is negligible.
- (a)** Calculate the maximum permissible noise power spectral density in watts/hertz referenced to the receiver input.
- (b)** What is the maximum permissible effective noise temperature in kelvin for the receiver if the antenna temperature is 290 K?
- (c)** What is the maximum permissible noise figure in dB for the receiver?
- 5.7.** A receiver preamplifier has a noise figure of 13 dB, a gain of 60 dB, and a bandwidth of 2 MHz. The antenna temperature is 490 K, and the input signal power is 10^{-12} W.
- (a)** Find the effective temperature, in kelvin, of the preamplifier.
- (b)** Find the system temperature in kelvin.
- (c)** Find the output SNR in decibels.

- 5.8.** Assume that a receiver has the following parameters: gain = 50 dB, noise figure = 10 dB, bandwidth = 500 MHz, input signal power = 50×10^{-12} W, source temperature, $T_A^o = 10$ K, line loss = 0 dB. You are asked to insert a preamplifier between the antenna and the receiver. The preamplifier is to have a gain of 20 dB and a bandwidth of 500 MHz. Find the preamplifier noise figure that would be required to provide a 10-dB improvement in overall system SNR.
- 5.9.** Find the maximum allowable effective system temperature, T_S^o , required to *just close* a particular link with a bit error probability of 10^{-5} for a data rate of $R = 10$ kbits/s. The link parameters are as follows: transmission frequency = 12 GHz, EIRP = 10 dBW, receiver antenna gain = 0 dB, modulation type is noncoherently detected BFSK, other losses = 0 dB, and the distance between transmitter and receiver = 100 km.
- 5.10.** Consider a receiver made up of the following three stages: The input stage is a preamplifier with a gain of 20 dB and a noise figure of 6 dB. The second stage is a 3-dB lossy network. The output stage is an amplifier with a gain of 60 dB and a noise figure of 16 dB.
- (a) Find the composite noise figure for the receiver.
 (b) Repeat part (a) with the preamplifier removed.
- 5.11.** (a) Find the effective input noise temperature, T_R^o , of a receiver comprised of three amplifier stages connected in series with power gains, from input to output, of 10, 16, and 20 dB, and effective noise temperatures, from input to output, of 1800, 2700, and 4800 K.
- (b) What would the gain of the first stage have to be to reduce the contribution to T_R^o of all stages after the first to 10% of the first-stage contribution?
- 5.12.** The effective temperature of a particular multiple-stage receiver is required to be 300 K. Assume that the effective temperatures and gains of stages 2 through 4 are as follows: $T_2^o = 600$ K, $T_3^o = T_4^o = 2000$ K, $G_2 = 13$ dB, and $G_3 = G_4 = 20$ dB.
- (a) Compute the required gain, G_1 , for the first stage, under the conditions that $T_1^o = 200, 230, 265, 290, 295,$ and 300 K.
 (b) Plot the G_1 versus T_1^o trade-off.
 (c) Regarding contributions to the effective temperature of the receiver, why is it reasonable in this case to ignore all stages beyond the fourth stage?
 (d) In a practical engineering trade-off between T_1^o and G_1 what range of T_1^o values do you think should be considered?
- 5.13.** A receiver consists of a preamplifier followed by multiple amplifier stages. The composite effective temperature of all the amplifier stages is 1000 K, referenced to the preamplifier output.
- (a) Compute the receiver effective noise temperature, referenced to the preamplifier input, for a single-stage preamplifier with a noise temperature of 400 K and gains of 3, 6, 10, 16, and 20 dB.
 (b) Repeat part (a) for a two-stage preamplifier with 400-K noise per stage and gains of 3, 6, 10, and 13 dB per stage.
 (c) Plot the receiver effective temperature versus the gain of the first stage for parts (a) and (b).
- 5.14.** (a) Equation (5.42) shows the composite noise figure for a network made up of a lossy line followed by an amplifier. Develop a general expression for the composite noise figure of three such networks connected in series.
 (b) Consider a network that is made up of an amplifier followed by a lossy line. Develop a general expression for the composite noise figure of three such networks connected in series.

- (c) A receiver is made up of the following component parts in series: Receiving antenna with temperature $T_A = 1160$ K, lossy line 1 with $L_1 = 6$ dB, amplifier 1 with noise figure $F_1 = 3$ dB and gain $G_1 = 13$ dB, lossy line 2 with $L_2 = 10$ dB, and amplifier 2 with noise figure $F_2 = 6$ dB and gain $G_2 = 10$ dB. The input signal is 80 picowatts (pW) and the signal bandwidth is 0.25 GHz. Trace the values of signal power, noise power, and SNR throughout the system.
- 5.15. (a)** An amplifier having a gain of 10 dB and a noise figure of 3 dB is connected to the output of a receiving antenna directly (no line loss between them). Following the amplifier is a lossy line with a loss factor of 10 dB. Consider that the input signal power is 10 pW, the antenna temperature is 290 K, and the signal bandwidth is 0.25 GHz. Find the SNR into and out of the amplifier, and out of the lossy line.
- (b)** Repeat part (a) with the antenna temperature equal to 1450 K.
- 5.16.** A receiver with 80-dB gain and an effective noise temperature of 3000 K is connected to an antenna that has a noise temperature of 600 K.
- (a)** Find the noise power that is available from the source over a 40-MHz band.
- (b)** Find the receiver noise power referenced to the receiver input.
- (c)** Find the receiver output noise power over a 40-MHz band.
- 5.17.** An antenna is pointed in a direction such that it has a noise temperature of 50 K. It is connected to a preamplifier that has a noise figure of 2 dB and an available gain of 30 dB over an effective bandwidth of 20 MHz. The input signal to the preamplifier has a value of 10^{-12} W.
- (a)** Find the effective input noise temperature of the preamplifier.
- (b)** Find the SNR out of the preamplifier.
- 5.18.** A receiver with a noise figure of 13 dB is connected to an antenna through 75 ft of 300- Ω transmission line that has a loss of 3 dB per 100 ft.
- (a)** Evaluate the composite noise figure of the line and the receiver.
- (b)** If a 20-dB preamplifier with a 3-dB noise figure is inserted between the line and the receiver, evaluate the composite noise figure of the line, the preamplifier, and the receiver.
- (c)** Evaluate the composite noise figure if the preamplifier is inserted between the antenna and the transmission line.
- 5.19.** A satellite communication system uses a transmitter that produces 20 W of RF power at a carrier frequency of 8 GHz that is fed into a 2-ft parabolic antenna. The distance to the receiving earth station is 20,000 nautical miles. The receiving system uses an 8-ft parabolic antenna and has a 100-K system noise temperature. Assume that each antenna has an efficiency of 0.55. Also assume that the incidental losses amount to 2 dB.
- (a)** Calculate the maximum data rate that can be used if the modulation is differentially coherent PSK (DPSK) and the bit error probability is not to exceed 10^{-5} .
- (b)** Repeat part (a) assuming that the downlink transmission is at a carrier frequency of 2 GHz.
- 5.20.** Consider that an unmanned spacecraft with a carrier frequency of 2 GHz and a 10-W transponder is in the vicinity of the planet Saturn (a distance of 7.9×10^8 miles from the earth). The receiving earth station has a 75-ft antenna and a system noise temperature of 20 K. Calculate the size of the spacecraft antenna that would be required to just close a 100-bits/s data link. Assume that the required E_b/N_0 is 10 dB and that there are incidental losses amounting to 3 dB. Also assume that each antenna has an efficiency of 0.55.

- 5.21. (a)** Assume a receiver front end with the following parameters: gain = 60 dB, bandwidth = 500 MHz, noise figure = 6 dB, input signal power = 6.4×10^{-11} W, source temperature, $T_A^\circ = 290$ K, line loss = 0 dB. A preamplifier with the following characteristics is inserted between the antenna and the receiver: gain = 10 dB, noise figure = 1 dB. Find the composite receiver noise figure, in decibels. How much noise figure improvement, in decibels, has been realized?
- (b)** Find the output SNR improvement, in decibels, as a result of the improved noise figure.
- (c)** Repeat part (b) for $T_A^\circ = 6000$ K. What is the output SNR improvement in decibels?
- (d)** Repeat part (b) for $T_A^\circ = 15$ K. What is the output SNR improvement in decibels?
- (e)** What conclusions can you draw from your answers with regard to how the improvement in output SNR tracks the improvement in noise figure? Explain.
- 5.22. (a)** Given the following link parameters, find the maximum allowable receiver noise figure. The modulation is coherent BPSK with a bit-error probability of 10^{-5} for a data rate of 10 Mbits/s. The transmission frequency is 12 GHz. The EIRP is 0 dBW. The receiving antenna diameter is 0.1 m (assume an efficiency of 0.55), and the antenna temperature is 800 K. The distance between the transmitter and receiver is 10 km. The margin is 0 dB and the incidental losses are assumed to be 0 dB.
- (b)** If the data rate is doubled, how will that affect the value of the noise figure in part (a)?
- (c)** If the antenna diameter is doubled, how will that affect the value of the noise figure in part (a)?
- 5.23. (a)** Ten users simultaneously access a nonregenerative satellite repeater with a 50-MHz bandwidth using an FDMA access scheme. Assume that each user's EIRP is 10 dBW; also assume that each user's coefficient $A_i = G_{rs}/L_s L_o = -140$ dB. What is the total power P_T received by the satellite receiver?
- (b)** Assume that the satellite system noise temperature is 2000 K. What is the value of the satellite receiver noise power in watts, referenced to the receiver input?
- (c)** What is the uplink SNR at the satellite receiver for each user's signal?
- (d)** Assuming the received power at the satellite from each user is the same, what fraction of the satellite EIRP is allocated to each of the 10 users' signals? If the satellite downlink EIRP_s = 1000 W, how many watts per user is downlinked?
- (e)** How much of the satellite EIRP is allocated to the transmission of uplink thermal noise?
- (f)** Is the satellite uplink limited or downlink limited? Explain.
- (g)** At the earth station, the receiver noise temperature is 800 K. What is the resultant (overall) average signal-to-noise power spectral density (P_r/N_0) for a single user's transmission across a 50-MHz band? Assume that the coefficient $\gamma = G_r/L_s L_o = -140$ dB.
- (h)** Recalculate P_r/N_0 for a single user's transmission, using an approximation resulting from your answer to part (f).
- (i)** In the absence of intermodulation noise, the following repeater relationship is often used:

$$\text{overall} \left(\frac{P_r}{N_0} \right)^{-1} = \text{uplink} \left(\frac{P_r}{N_0} \right)^{-1} + \text{downlink} \left(\frac{P_r}{N_0} \right)^{-1}$$

Recalculate P_r/N_0 using this relationship, and compare the result with your answers to parts (g) and (h):

- 5.24.** How many users can simultaneously access a nonregenerative satellite repeater with a 100-MHz bandwidth, such that each user is allocated 50 W of the satellite's EIRP of 5000 W? At the satellite, the effective system temperature $T_s^o = 3500$ K. Assume that each user's uplink EIRP is 10 dBW and that the $G_r/L_s L_o$ term that reduces this EIRP at the satellite receiver is equal to -140 dB for each user.
- 5.25.** An AWGN channel has the following parameters and requirements: The data rate = 2.5 Mbits/s; the modulation is coherent BPSK with perfect frequency-, carrier-, and timing-synchronization, and the required bit-error probability is 10^{-5} ; the carrier frequency is 300 MHz; the distance between transmitter and receiver is 100 km; the transmitter power is 10^{-3} Watt; the transmit and receive antennas each have a diameter of 2 m and an efficiency of 0.55; the receiver-antenna temperature is 290 K; the line, from the receiver-antenna output to the receiver input has a loss factor, of 1 dB; there are no other losses. Find the maximum receiver noise figure in dB that can be used to *just* close the link.
- 5.26.** A wristwatch radio is to transmit and receive 1 Mbit/s data with a bit-error probability of 10^{-7} . It is to operate over a range of 10 km at a carrier frequency of 3 GHz. The modulation is DPSK, and the G/T^o is -30 dB/K. Such a radio might be used in a moving vehicle and subject to a fading-signal loss. The radio designer wants to examine the trade-off between minimizing the required EIRP and maximizing the fading loss that can be sustained. Produce a table showing several EIRP versus fading-loss values to help in selecting the needed battery. Consider the EIRP values of interest to be in the range of 300 mW to 10 W. Is it possible to meet the system specifications with a fading loss of 20 dB and an EIRP under 10 W?
- 5.27.** The designer decides that the wristwatch radio in Problem 5.26 does not have to meet the stated specifications while in a moving vehicle, and hence the fading loss can be established as 0 dB. Assume that the minimum allowable EIRP associated with this 0-dB loss is chosen for the transmitter (from the solution to Problem 5.26). What is the minimum value of transmitter power that can be used if the effective area of the transmitting antenna is 25 cm^2 ?

QUESTIONS

- 5.1.** Why is *free-space loss* a function of wavelength? (See Section 5.3.3.)
- 5.2.** What is the relationship between received signal-to-noise (S/N) ratio and carrier-to-noise (C/N) ratio? (See Section 5.4.)
- 5.3.** How much *link margin* is enough? (See Section 5.4.3.)
- 5.4.** There are two primary sources of noise and interference degradation at the input of a receiver. What are they? (See Section 5.5.5.)
- 5.5.** In order to achieve equitable sharing of a *nonregenerative* satellite repeater, what important relationship must exist among multiple users? (See Section 5.7.1.)

EXERCISES

Using the Companion CD, run the exercises associated with Chapter 5.